

Module 3

Documentation
Key Concept Product development

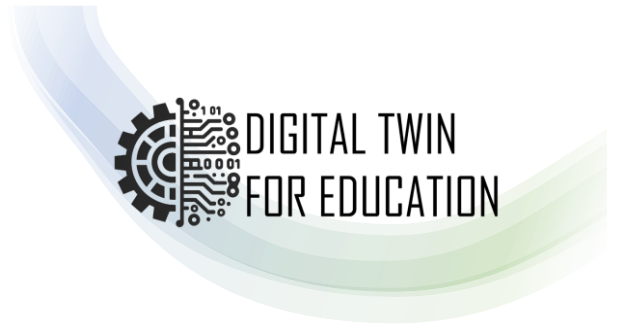

DIGITAL TWIN FOR EDUCATION

Course materials

Digital twin documentation
Key concept for product development

Status: Dez 2025

Author: Dr. K. Krettenauer
C. Schmid
B. Geibel

Module 3

Documentation
Key Concept Product development

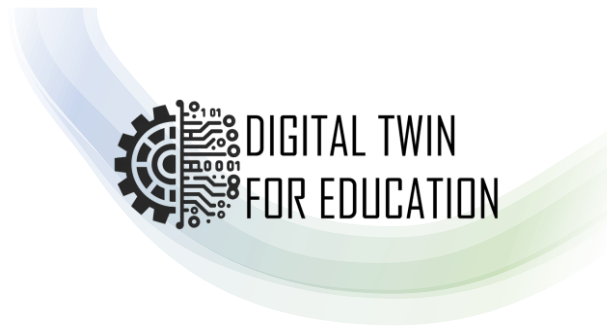
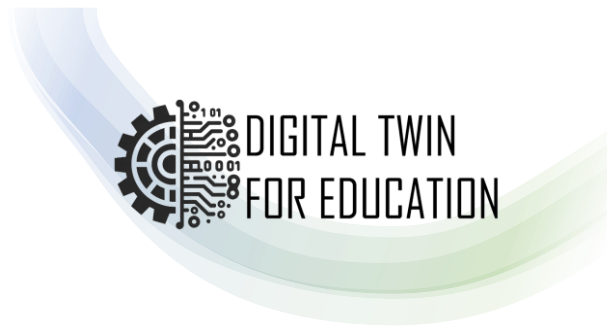

Table of Contents

0	Model analysis with task	3
1	Open Siemens NX MCD, import the project, and save it	6
2	Definition of rigid bodies	11
3	Definition of collision body.....	13
4	Testing and simulating the current status.....	17
5	Creating connections – defining the sliding joints.....	18
6	Testing and simulating the current status.....	22
7	Implementation of position monitoring on actuators.....	23
8	Integration of transport surfaces.....	26
9	Interim test of actuators (cylinders and conveyor belt).....	28
10	Integration of end position monitoring on actuators.....	32
11	Function test of end position monitoring on actuators	35
12	Integration of buttons in the NX model	37

Module 3

Documentation
Key Concept Product development



0 Model analysis with task

The NX model used for this exercise contains two pneumatic cylinders and a conveyor belt.

The task of the system is to first push a workpiece (rectangular body) laying on a plate with two pneumatic cylinders and then transport the workpiece away using the conveyor belt.

An additional start button can be used to initiate a sequence of steps for the sequence control. The double-acting pneumatic cylinders are controlled via solenoid valves and their position is monitored by limit switches.

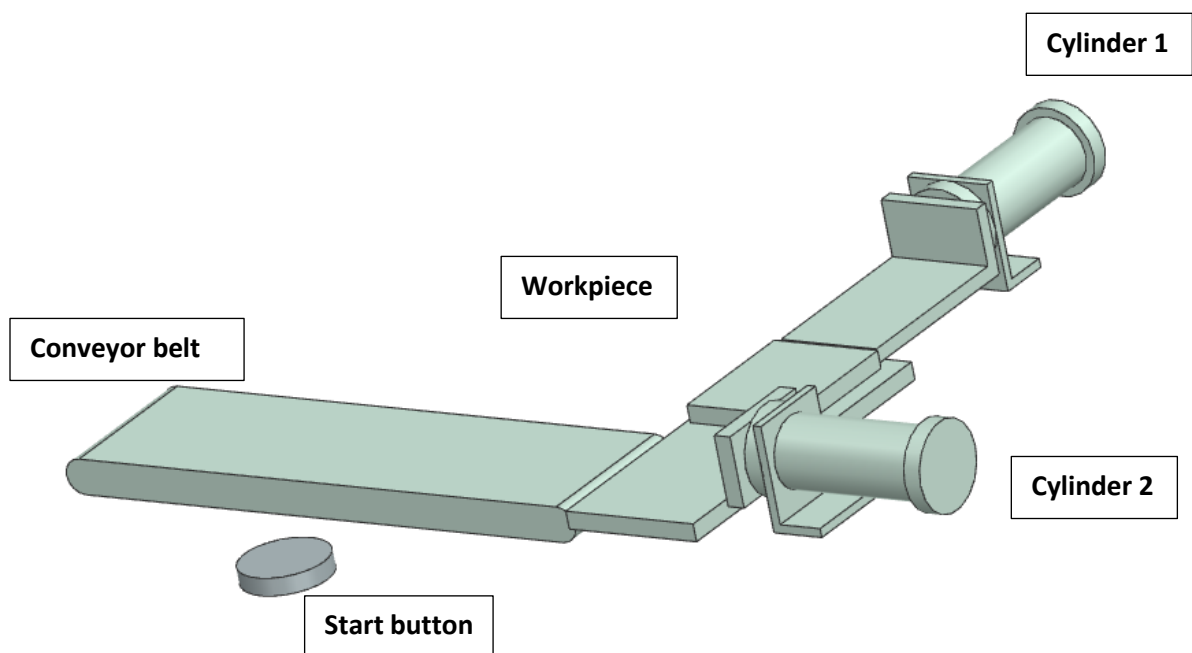

Module 3

Documentation Key Concept Product development

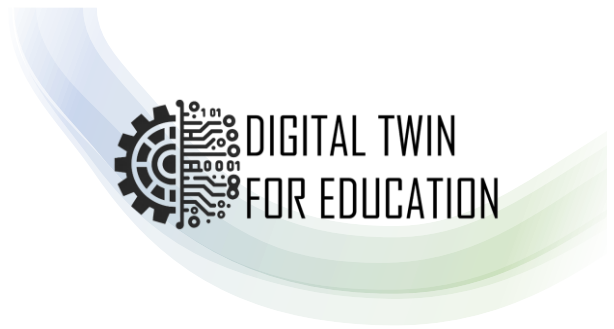

In the following work process, the already existing CAD model (assembly in STEP file format) is imported to Siemens NX MCD .

Parts of it will be made „physically“ movable so that the model can then be linked to a control system (PLC SIM advanced) and the associated programming environment (TIA-Portal) .

The whole work process is divided into five sections.

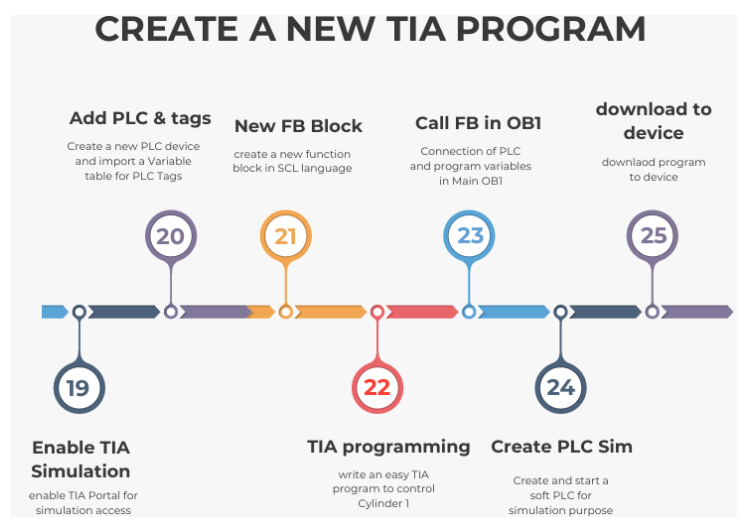
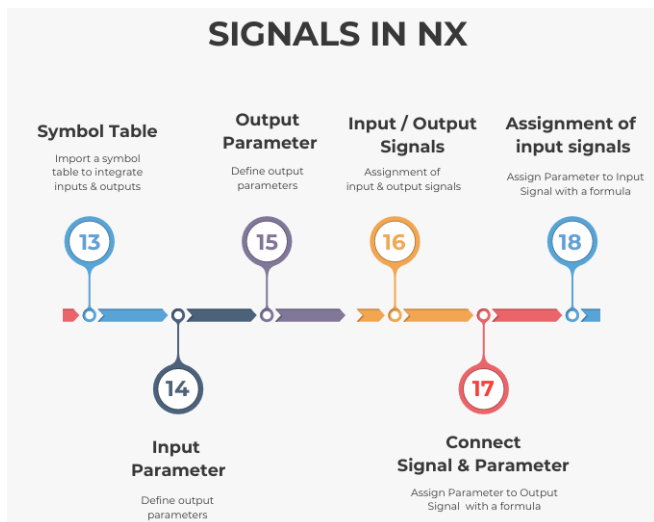
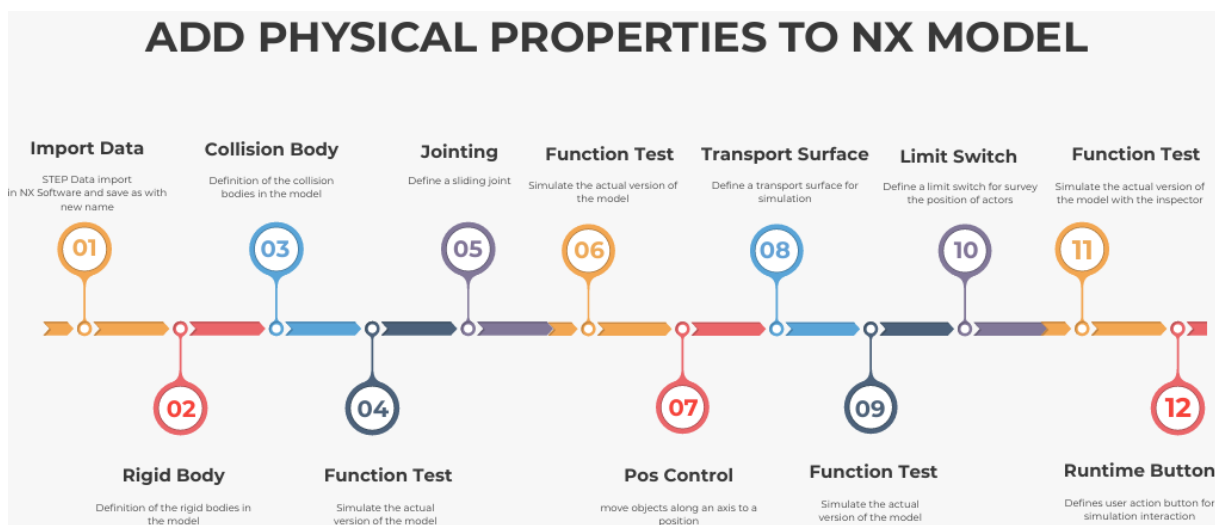

Module 3

Documentation Key Concept Product development

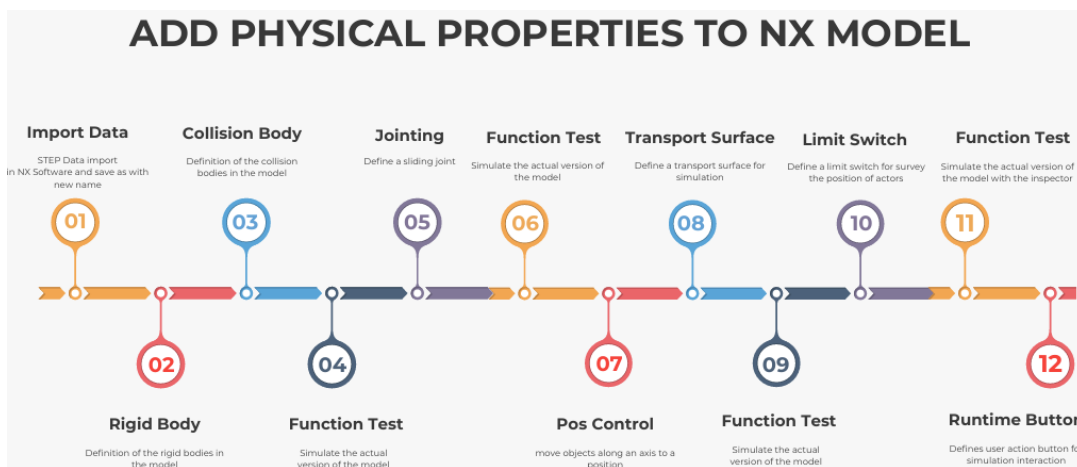
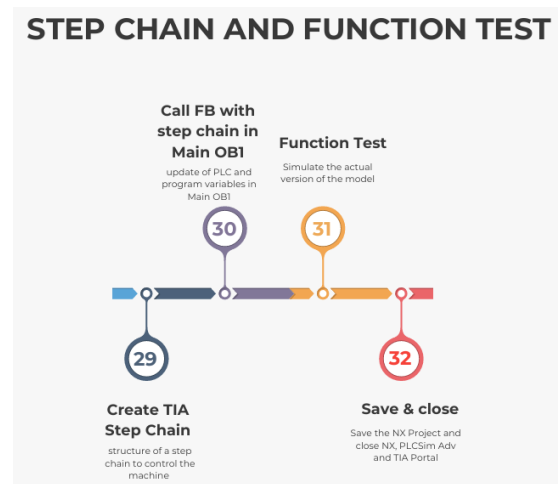
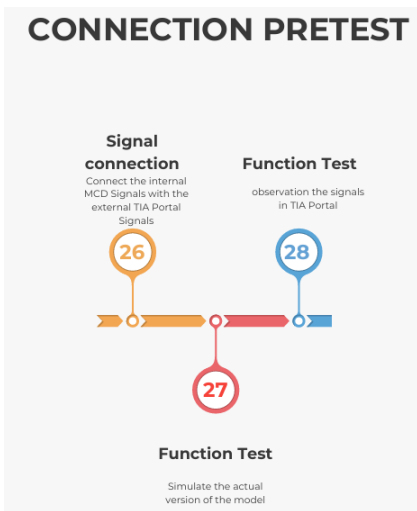
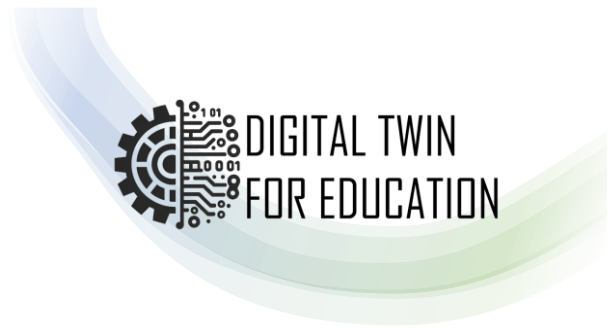

In this section we import an already existing simple CAD model to NX MCD and we will add physical behavior to the CAD model.

We use the concept of rigid bodies and collision bodies in order to simulate the effects of gravity, collision and friction. Joints between the bodies are used to make the bodies movable. Position controls are defined to limit and control the motion.

Module 3

Documentation
Key Concept Product development

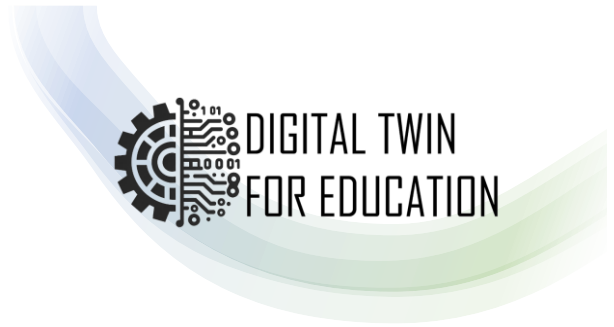

1 Open Siemens NX MCD, import the project, and save it

Video: 01Start-Import-Save

To use the software for modeling a digital twin, the **NX Mechatronics Concept Designer (MCD)** icon must be launched.

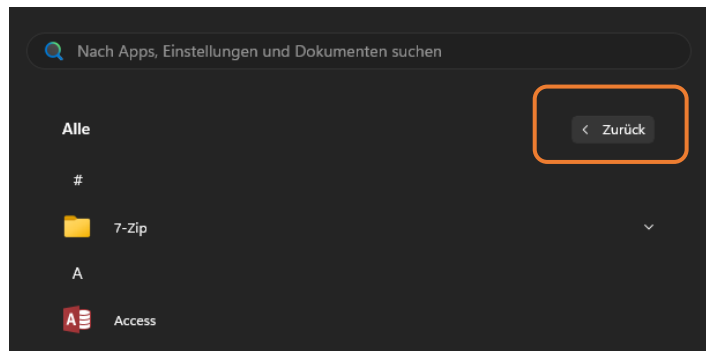
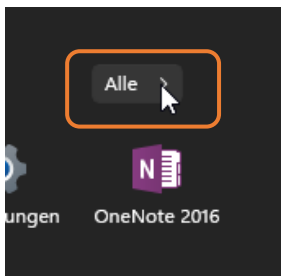

scroll here

Module 3

Documentation Key Concept Product development

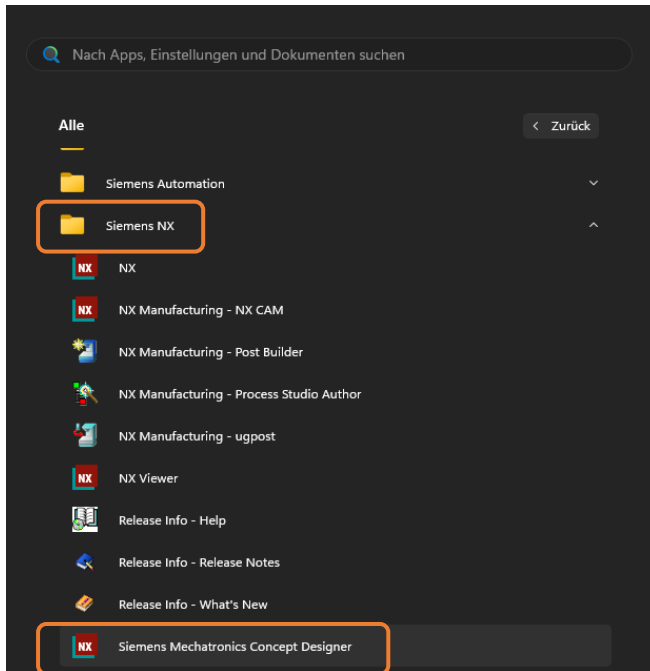
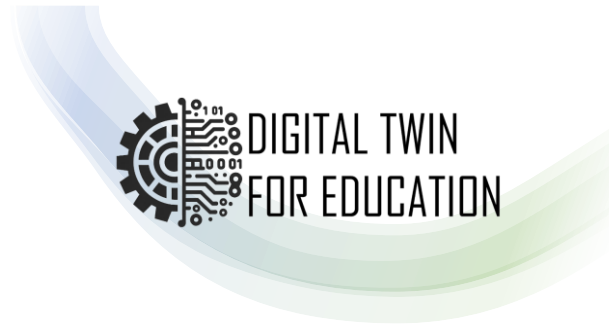

Once the NX interface has been opened, a pre-created STEP file can be imported using the OPEN icon. Before doing so, you must select "All Files" above the OK and Cancel buttons in order to view the STEP file.

Module 3

Documentation Key Concept Product development

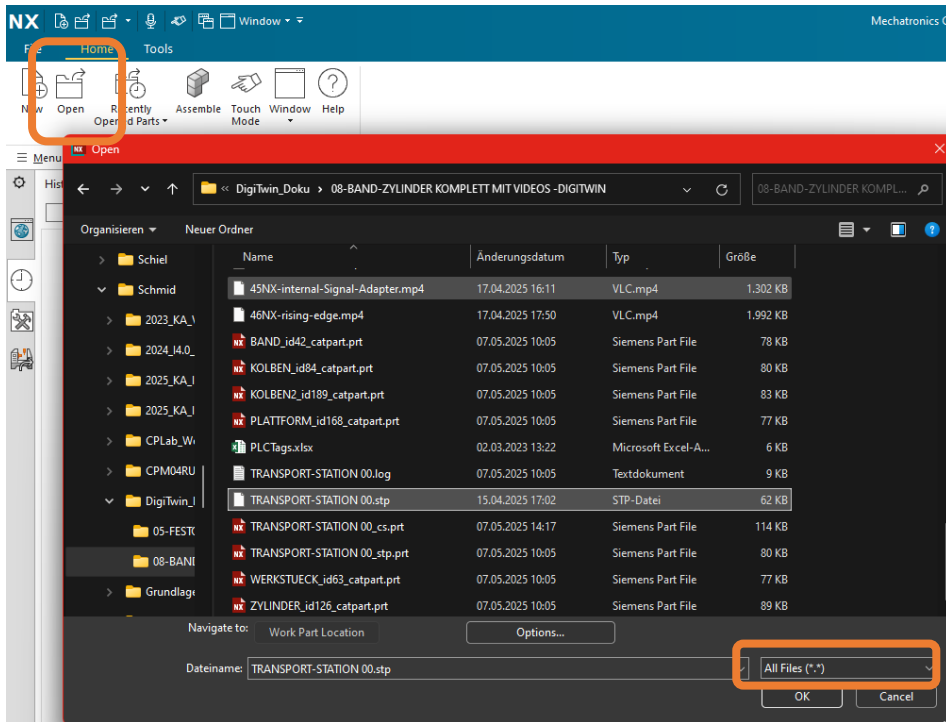
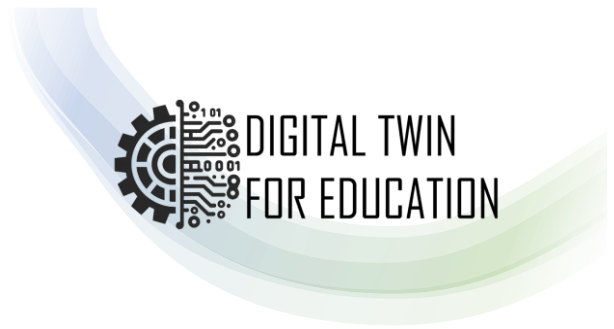

The STEP file TRANSPORT-STATION00.stp can then be imported into Siemens NX MCD and saved as a new project with the extension .prt (Part) using Save As.

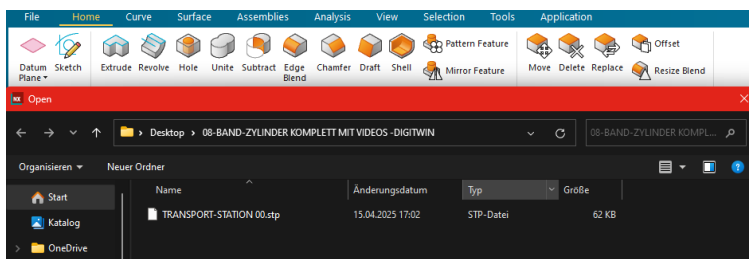

Save as with your own initials xy in the the file name TRANSPORT-STATION 00_xy.prt .

Module 3

Documentation Key Concept Product development

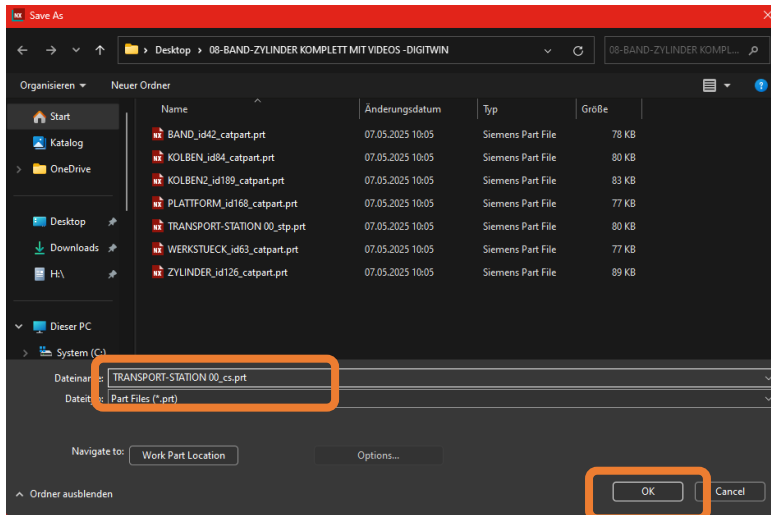
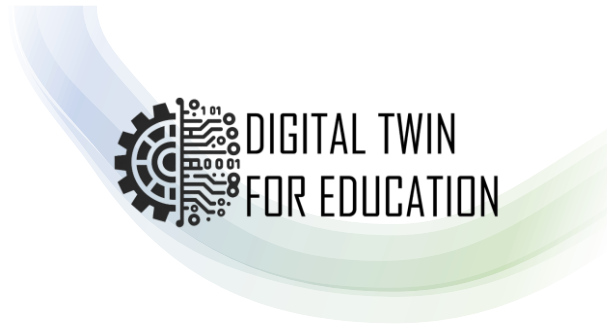

The MCD tool can then be started expand– **"More"** icon in the header and choose→Mechatronics Concept Designer

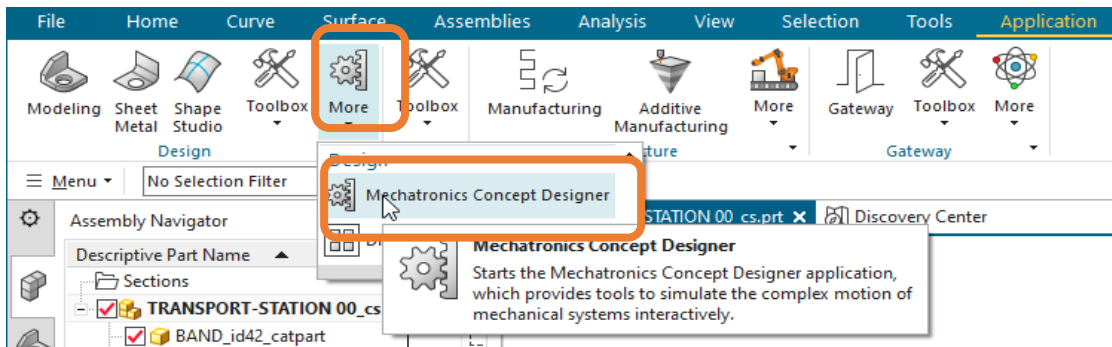

Opening the MCD module automatically opens the Physics Navigator.

Module 3

Documentation Key Concept Product development

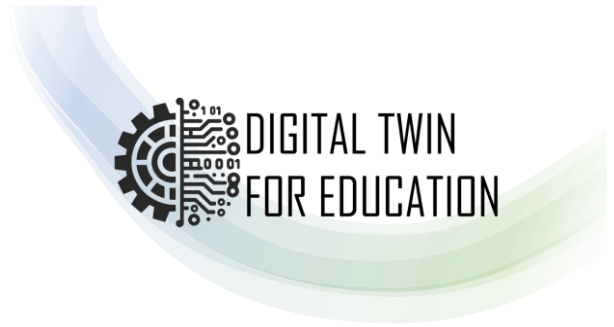

In this project, you can see that no definitions have been made yet. The Physics Navigator is still completely empty.

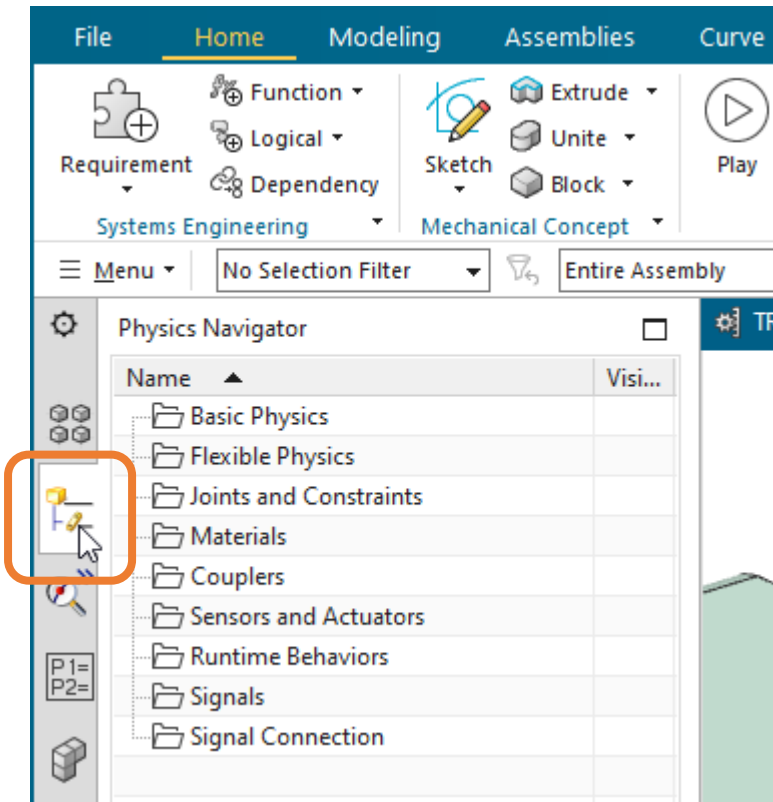

Module 3

Documentation
Key Concept Product development

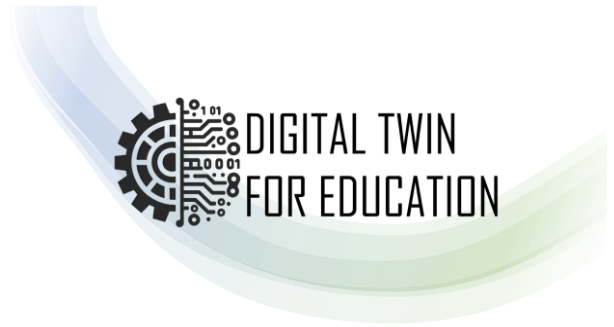

2 Definition of rigid bodies

Video: 02Rigid Bodies

It is suitable to apply the following rules.

Every component that should be movable in the later process must be defined as a **rigid body** in the



NX model. A **rigid body** is defined as a **Rigid Body**

In order to assign correctly the rigid bodies, you must first consider which components should be movable.

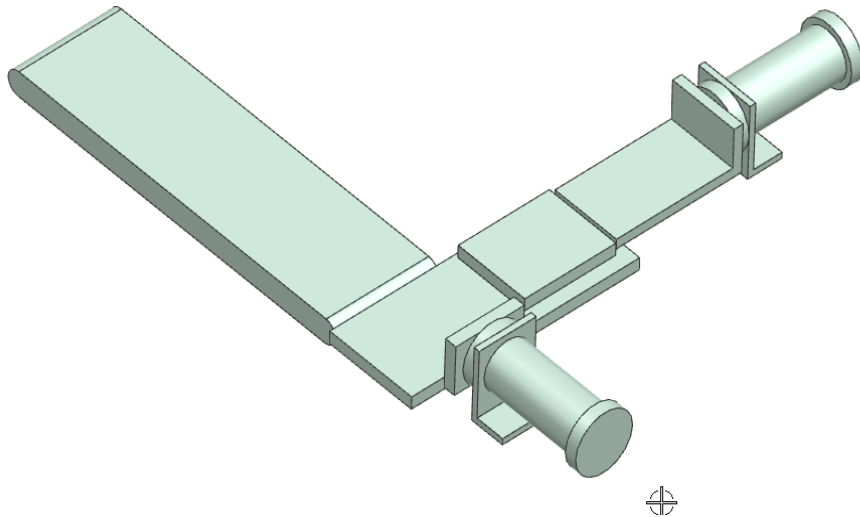

Module 3

Documentation
Key Concept Product development

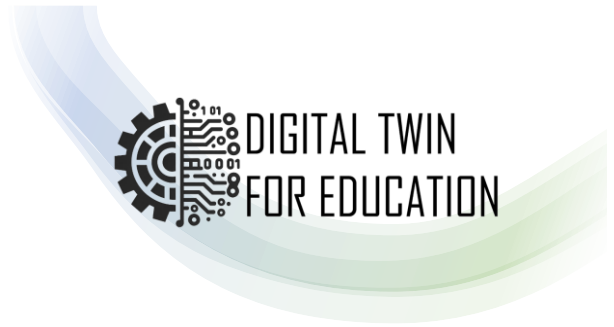

In this model, the **two cylinder Pistons** and the **workpiece** must be defined as rigid bodies, as these **three components** are supposed to be moveable in the simulation.

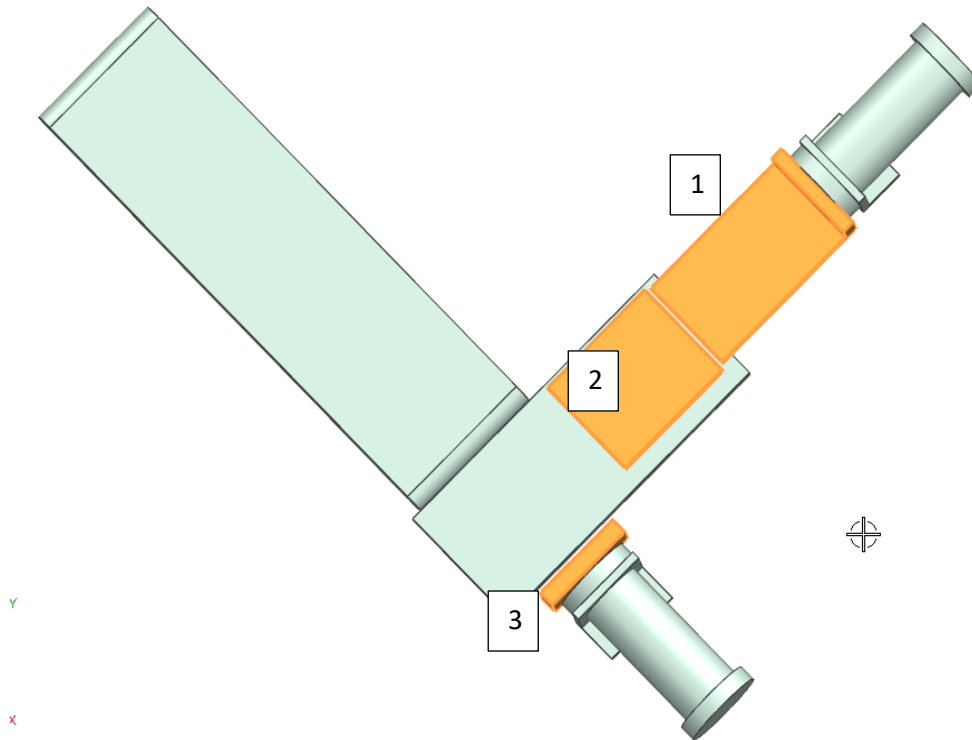

Module 3

Documentation
Key Concept Product development

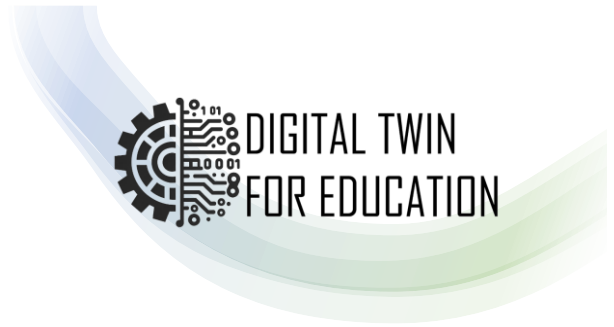

3 Definition of collision body

Video: 03Collision bodies

All components that are supposed to potentially collide with each other in the subsequent process must be defined as collision bodies. Single Parts or surfaces are defined as **Collision Body**.

The collision body property allows bodies (such as cylinders) to move and push other bodies (such as the workpiece) away. In this example, cylinder 1 pushes the workpiece in front of the second cylinder, which then pushes the workpiece onto the conveyor belt.

Similarly, the transport surface must be defined as a collision body so that the workpiece on the conveyor belt can be transported after the cylinders have been moved.

Attention: collision bodies are continuously surveyed during simulation, therefore they are consuming a lot of computer-power. They have to be applied in an economical way.

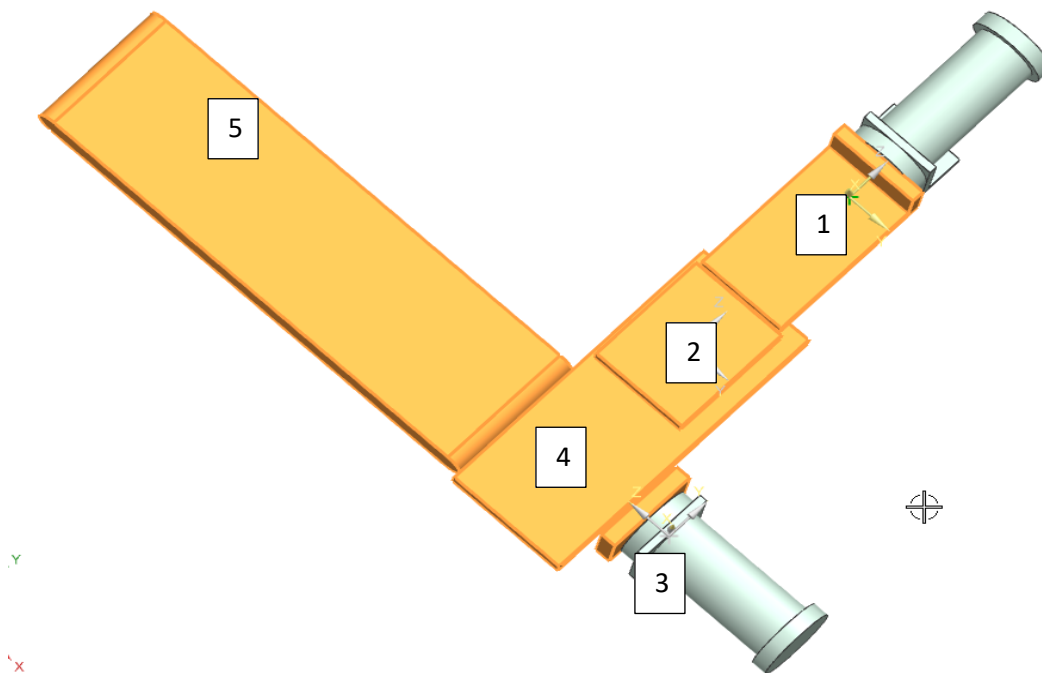

Module 3

Documentation Key Concept Product development

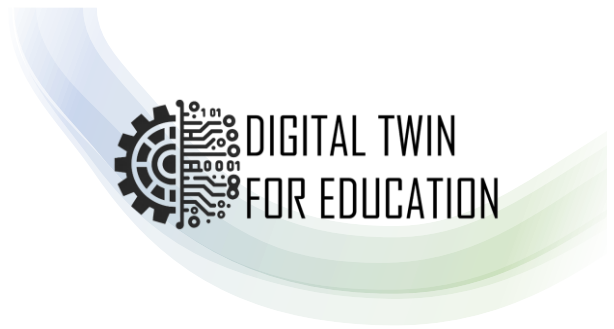

To define collision bodies, surfaces must be selected. In this example, the surface and the front of the ejector cylinder were selected.

The shape of the collision surface is defined as a "box." Due to the two surfaces selected so far and the "box" collision shape, the pink border is still tilted as a box.

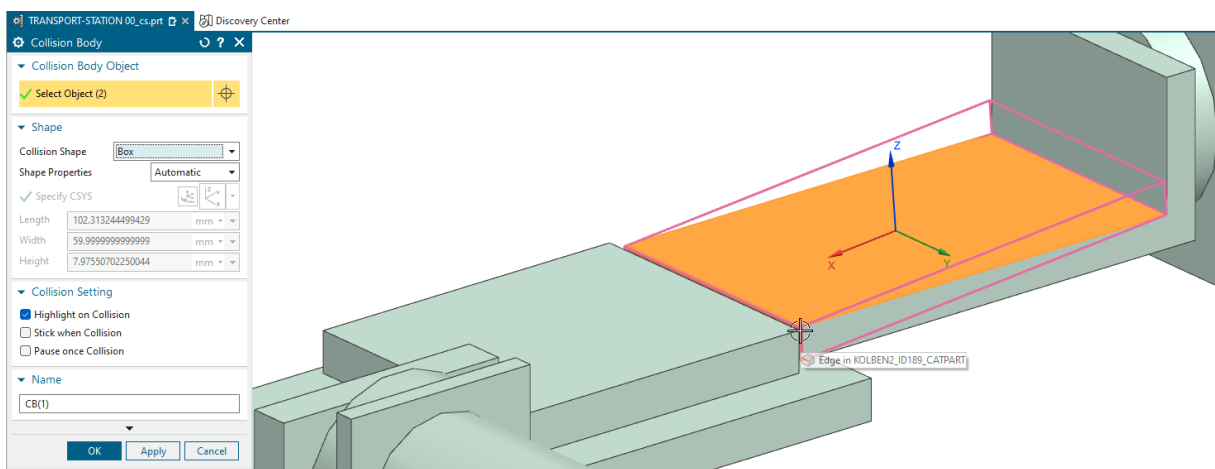

When a third and fourth surface are selected to define the collision body more precisely, the entire collision surface changes automatically and the pink border fits to the ejector cylinder. To do this, the side surfaces were also selected.

In most cases, it is sufficient to select three surfaces to define the collision body.

Please compare your result to the video.

Module 3

Documentation
Key Concept Product development

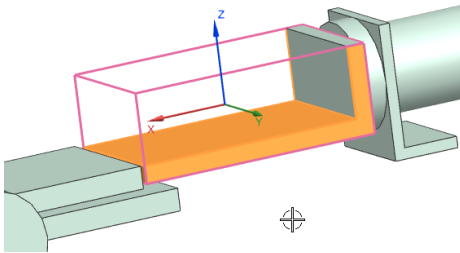
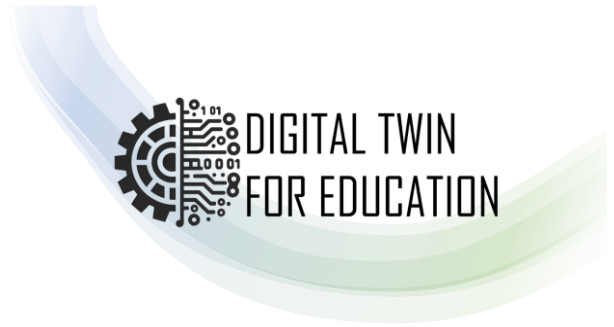

In the Physics Navigator, the collision surface created is stored in the project tree behind the rigid body.

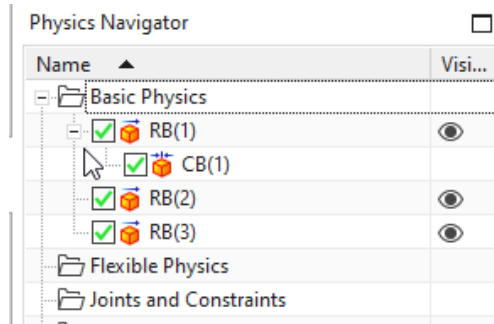
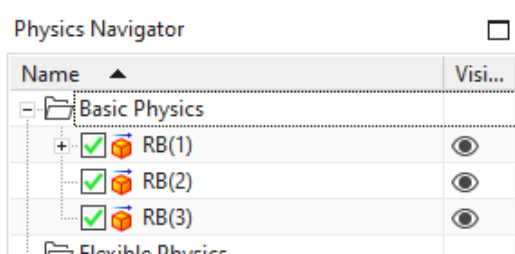

Once all collision bodies for the tasks have been defined, they should be displayed in the Physics Navigator as shown below.

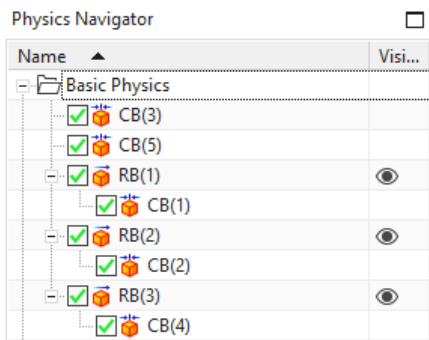

It is important to save the intermediate results regularly.

Module 3

Documentation Key Concept Product development

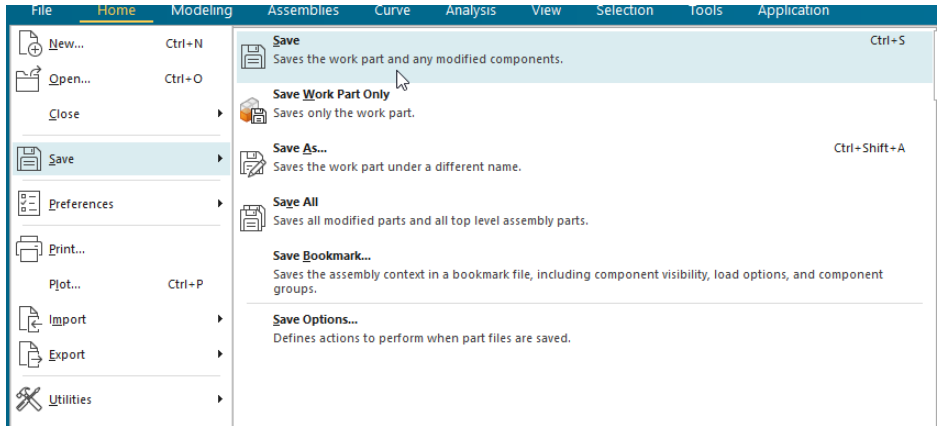
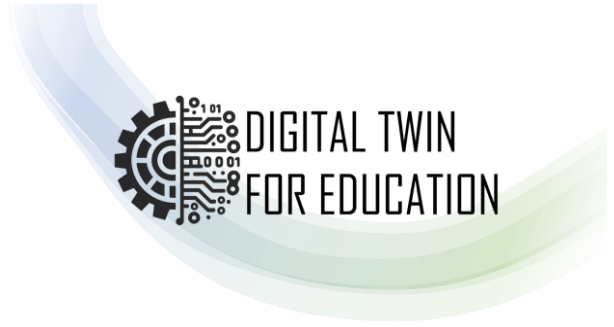

Module 3

Documentation
Key Concept Product development

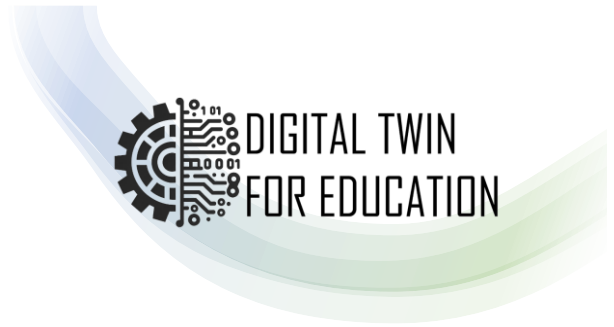

4 Testing and simulating the current status

Video: 04Test run

You can test the intermediate results at any time – the simulation is started using the Play button.

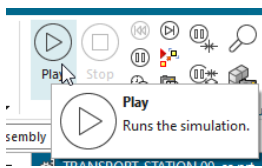

When the simulation is started, the two cylinders simply fall off. The reason for this is that the push cylinders have not yet been attached via push joints. These connections will be made in the next step.

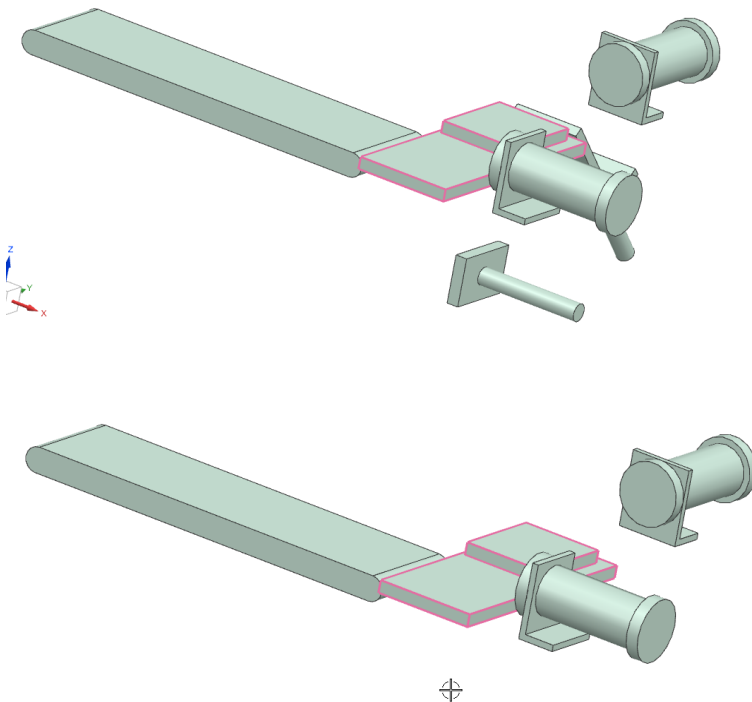

After testing, stop the simulation again using the stop button.

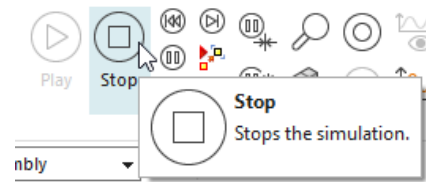

Module 3

Documentation Key Concept Product development

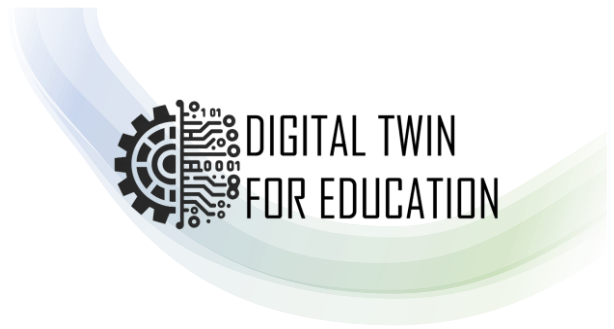

5 Creating connections – defining the sliding joints

Video: 05Joints

To make cylinder pistons 1 & 2 movable, there must be defined joints. This property makes the cylinder pistons movable and allows them to extend and retract in a targeted manner.

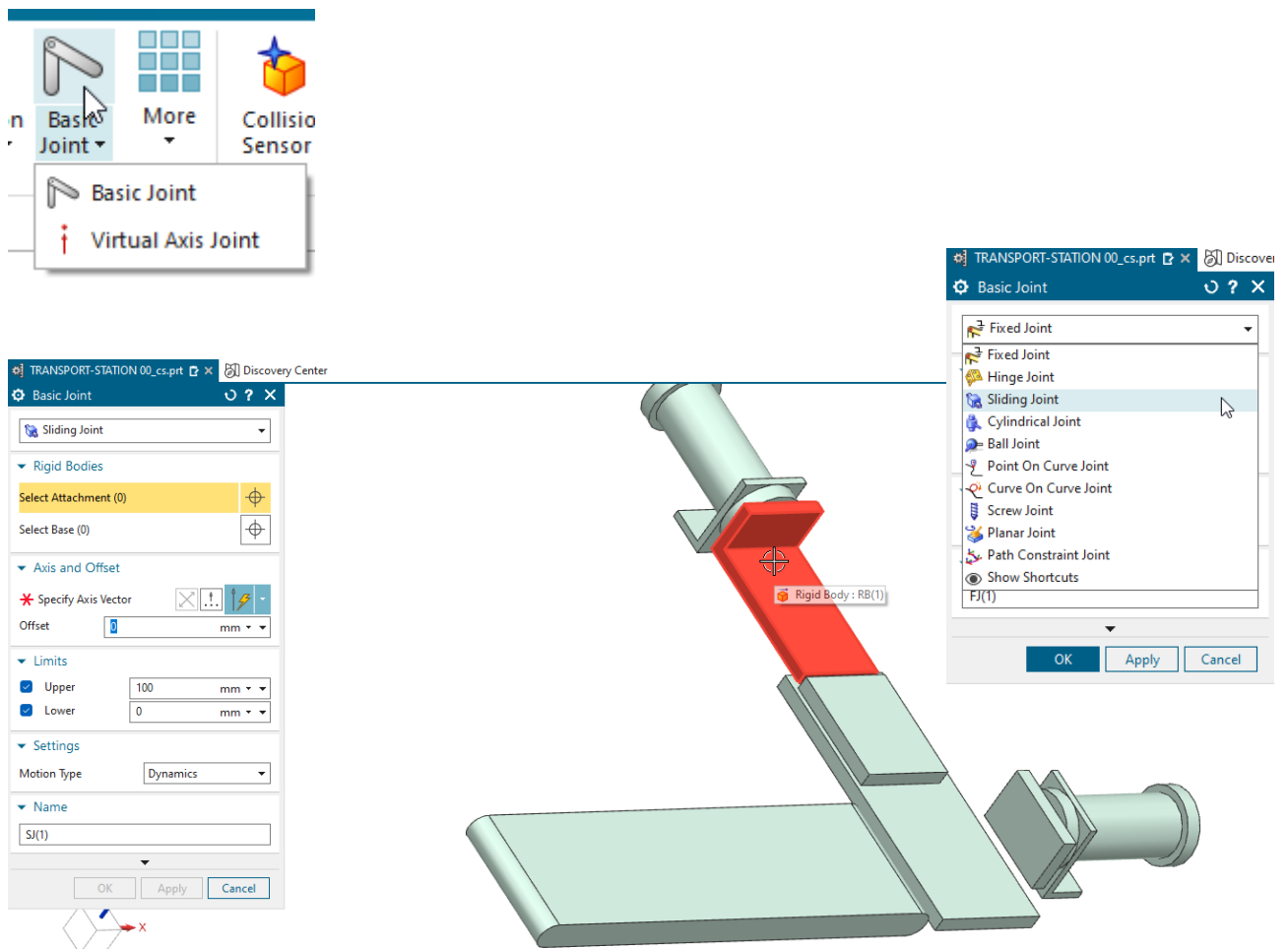

Module 3

Documentation Key Concept Product development

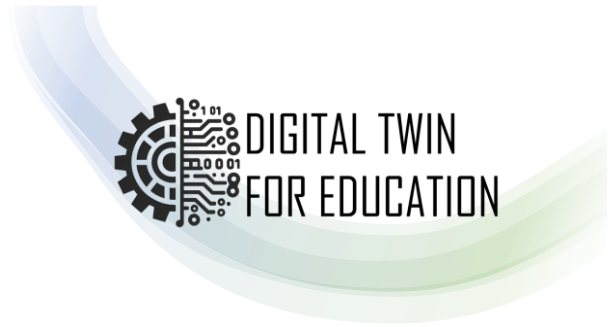

After selecting the cylinder/piston rod, the movement vector (the extension direction) must be defined.

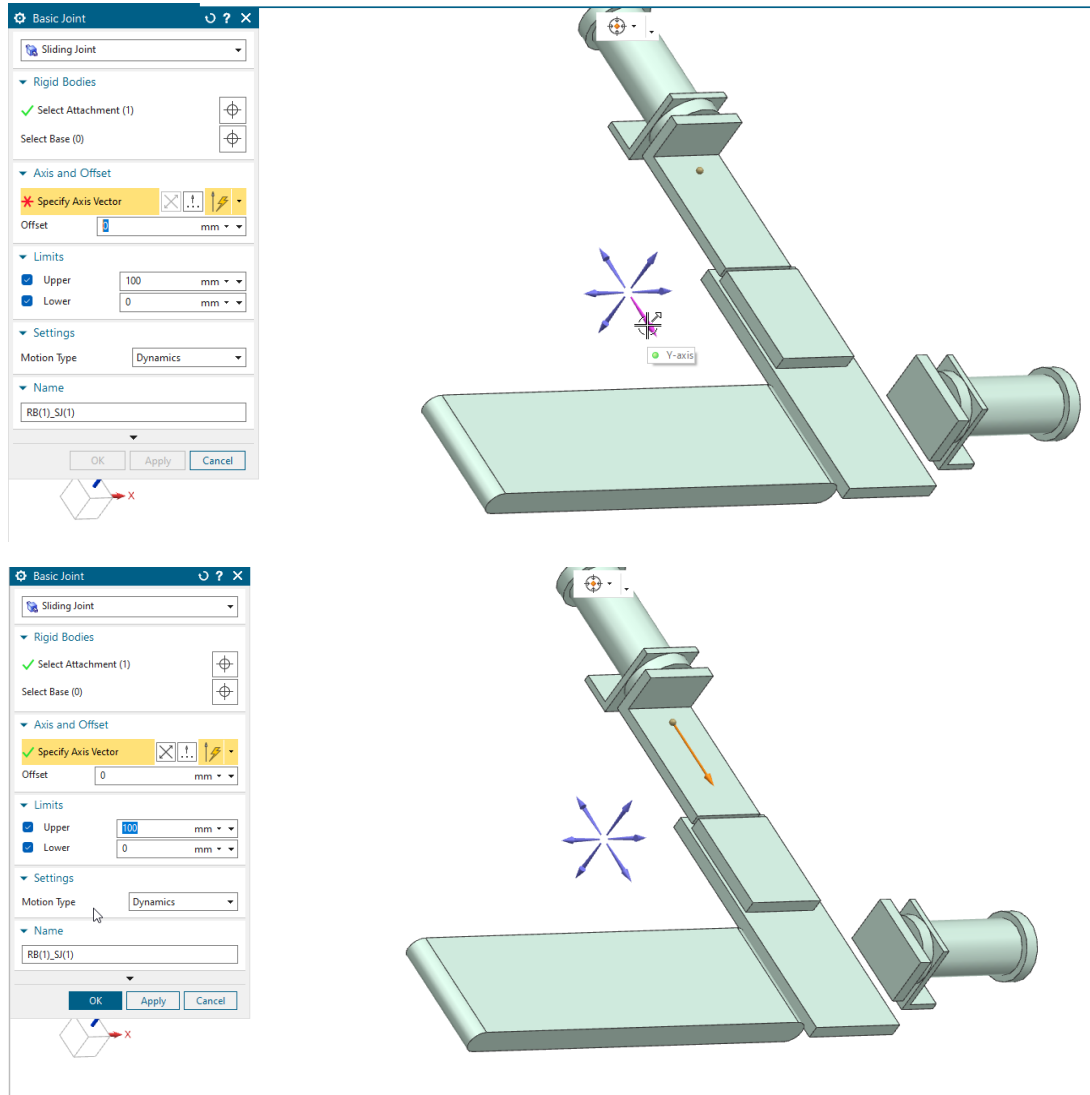

Module 3

Documentation Key Concept Product development

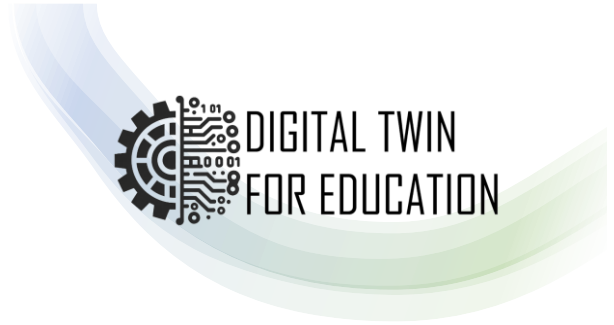

The procedure is then repeated for the second cylinder, also as a sliding joint. The procedure is analogous to that for the first cylinder.

First, select the body of the cylinder.

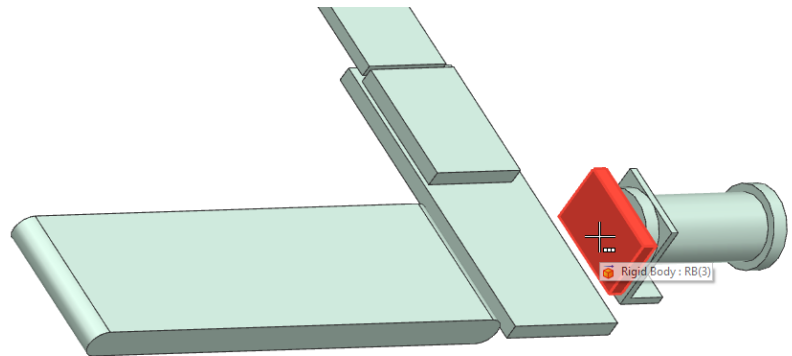

Then confirm the movement vector.

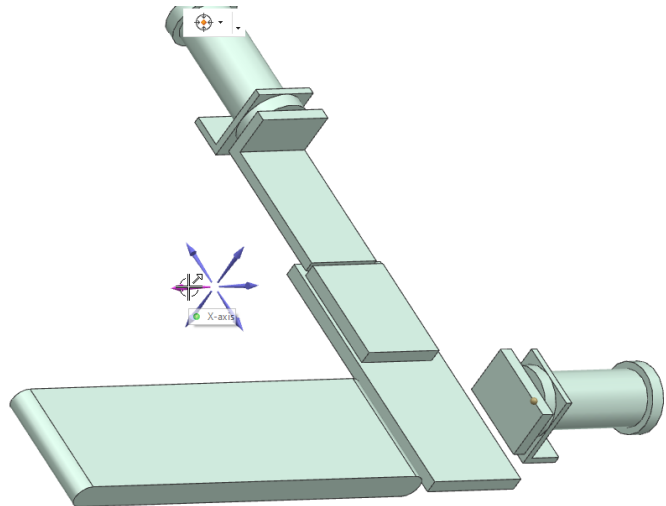
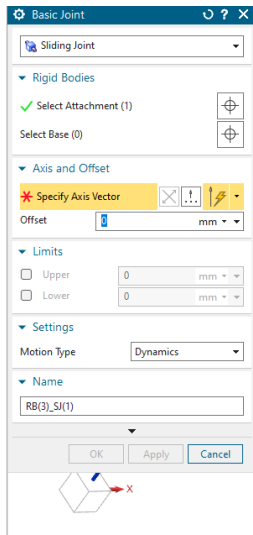

Module 3

Documentation Key Concept Product development

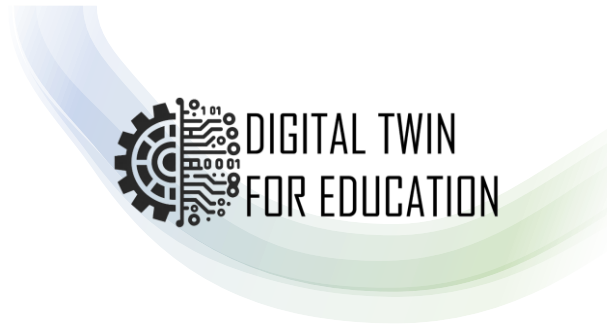

The maximum travel distance of the cylinder is defined in the Limits section – in our example, 100 mm.

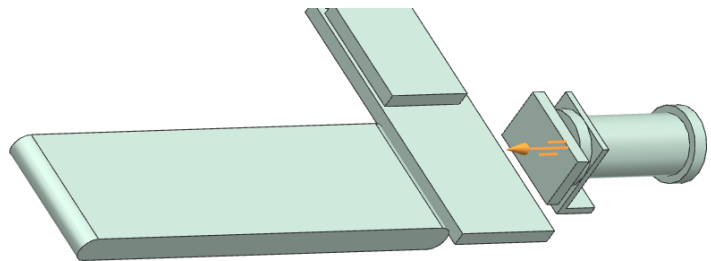
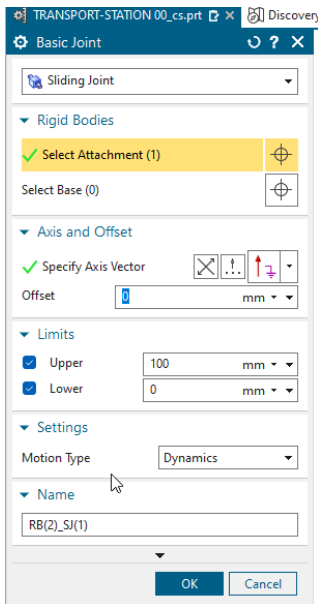

Module 3

Documentation
Key Concept Product development

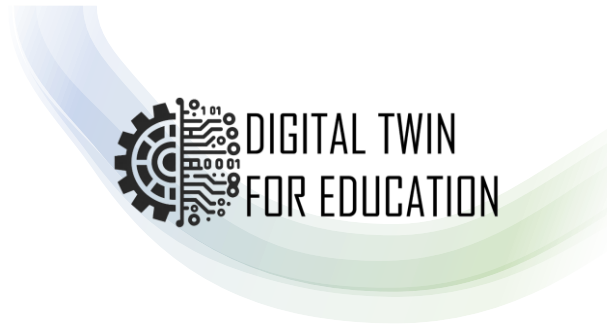

6 Testing and simulating the current status

Video: 06Test joints

It is always advisable to test the intermediate status – therefore, the simulation is now started with the Run button.

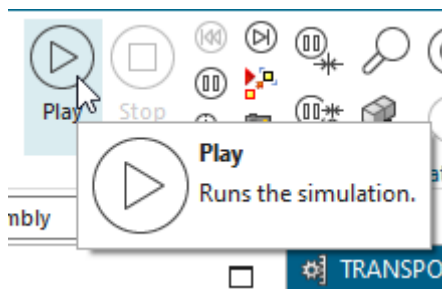

After starting the simulation (Run mode), the thrust joints can be moved using the mouse.

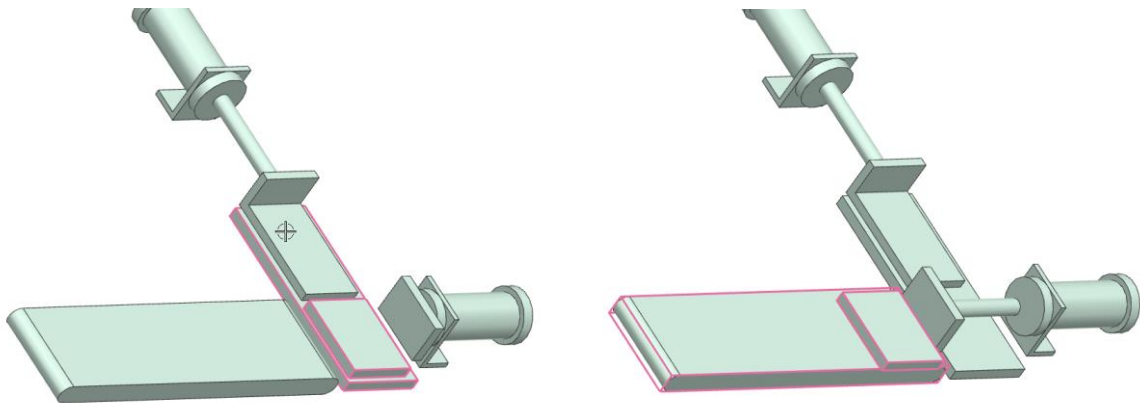

Module 3

Documentation
Key Concept Product development

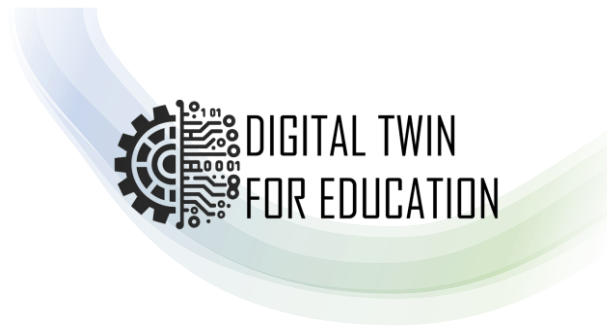

7 Implementation of position monitoring on actuators

Video: 07Pos-Controls

These steps give the cylinders their range of motion. In the case of the cylinder, this is extension and retraction using solenoid valves → MB1 and MB2 for cylinder 1.

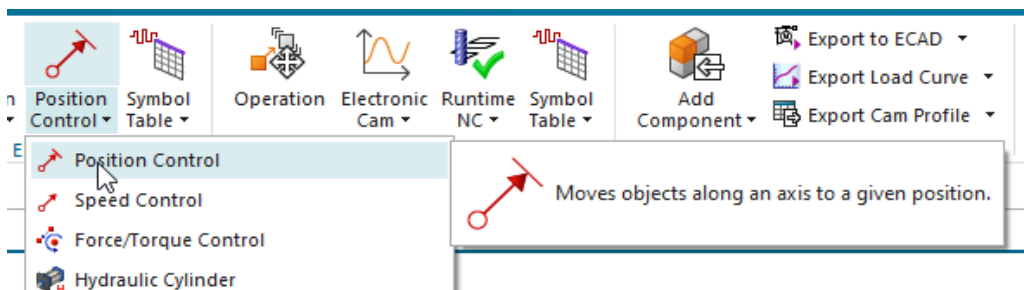

Solenoid valve 1 → MB1

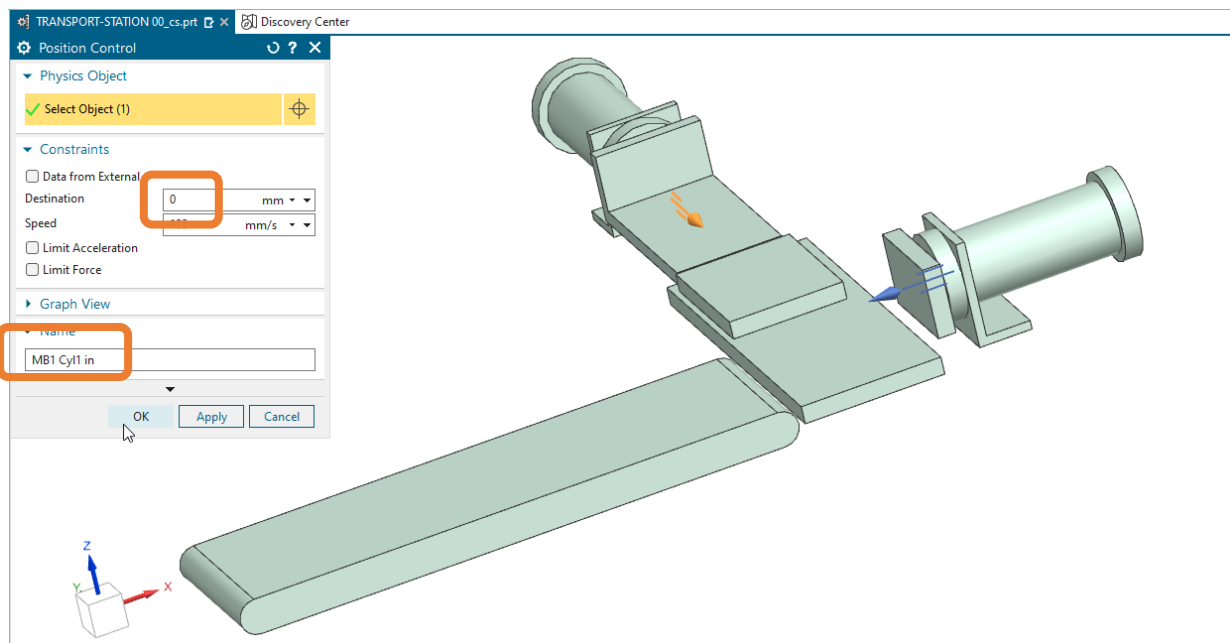

Module 3

Documentation Key Concept Product development

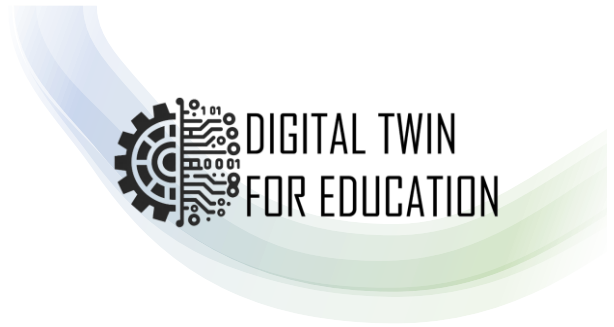

Solenoid valve 2 → MB2

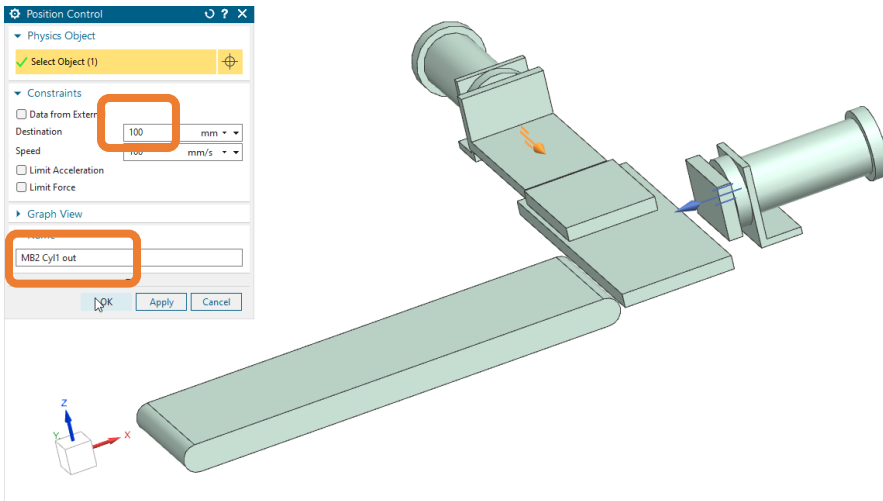

Solenoid valve 3 → MB3

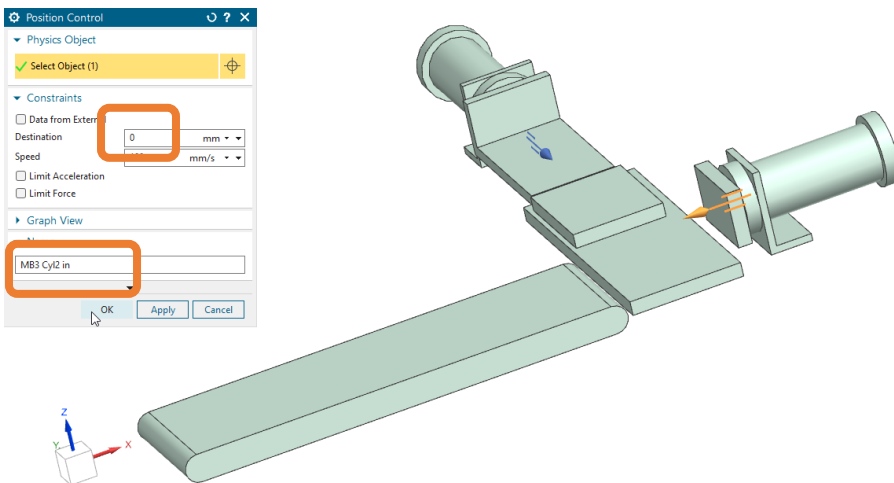

Module 3

Documentation Key Concept Product development

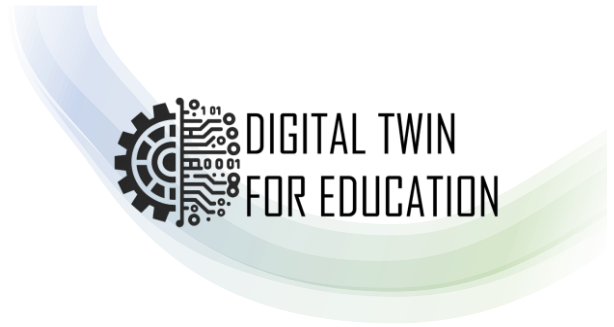

Solenoid valve 4 → MB4

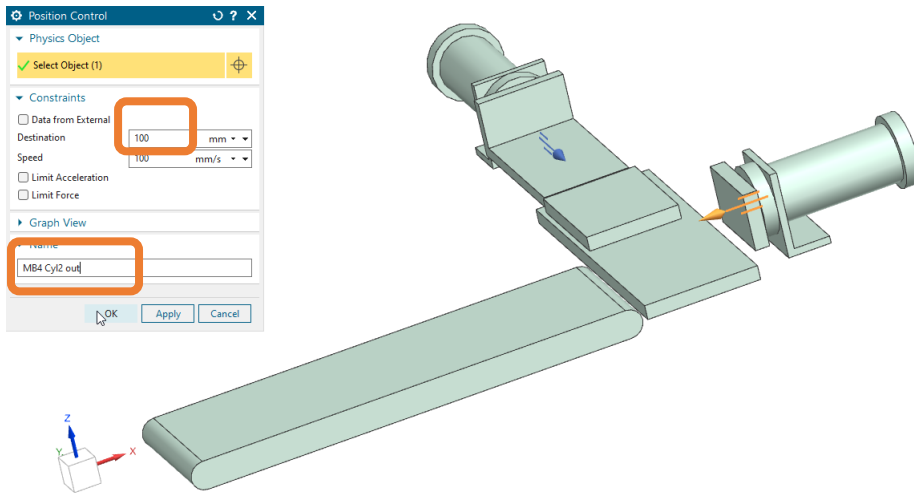

Module 3

Documentation
Key Concept Product development

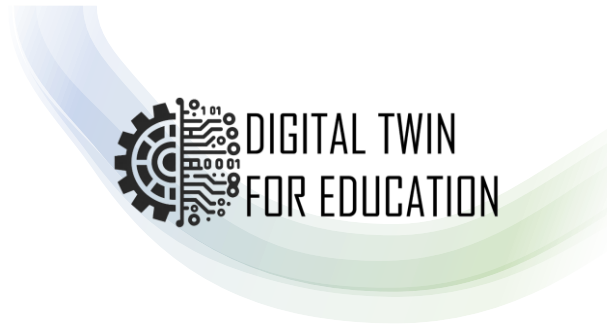

8 Integration of transport surfaces

Video: 08Conv-Belt

In order to transport the workpiece to the next station on a conveyor belt after it has been handled by the two cylinders, this transport surface must be defined.

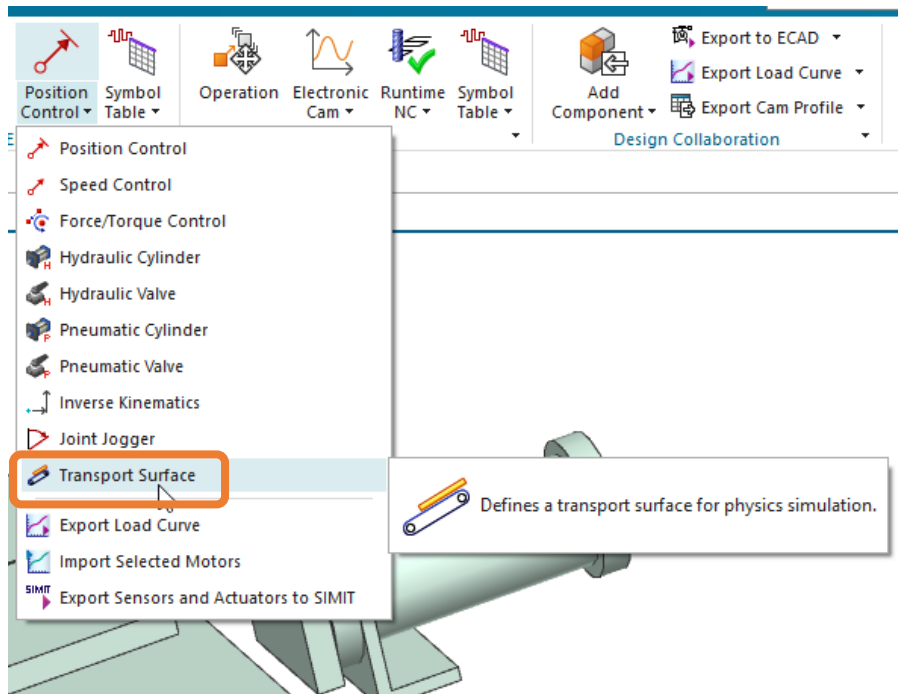

Module 3

Documentation
Key Concept Product development

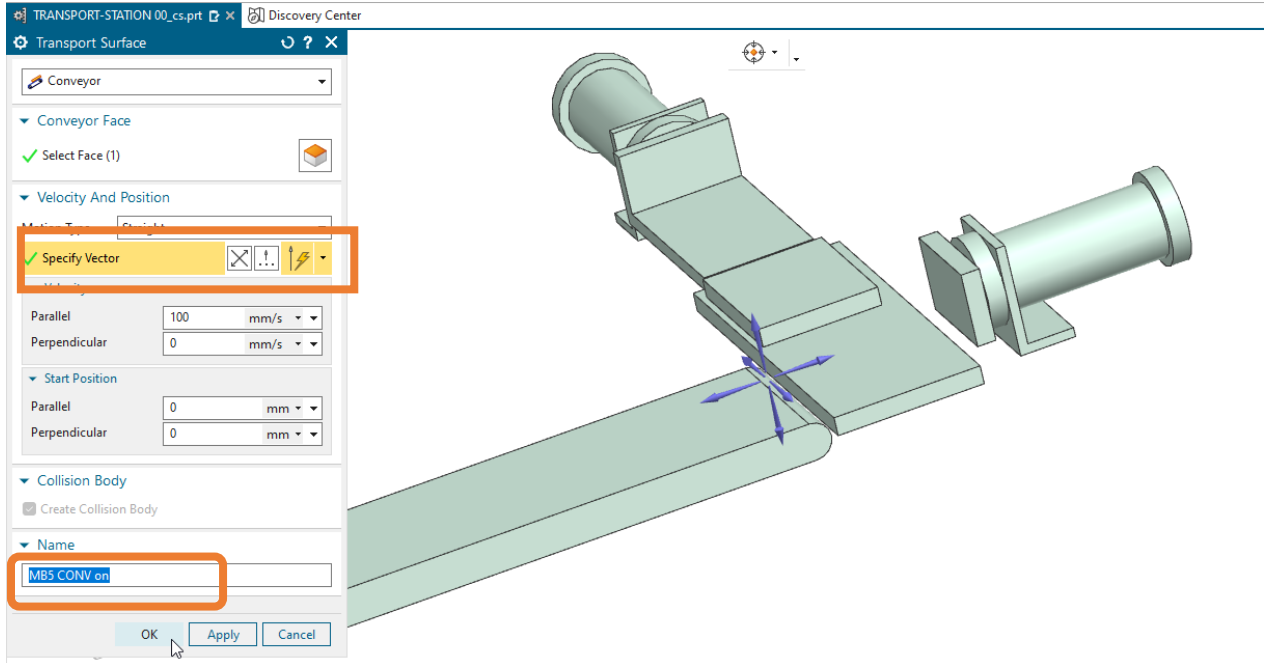

Module 3

Documentation Key Concept Product development

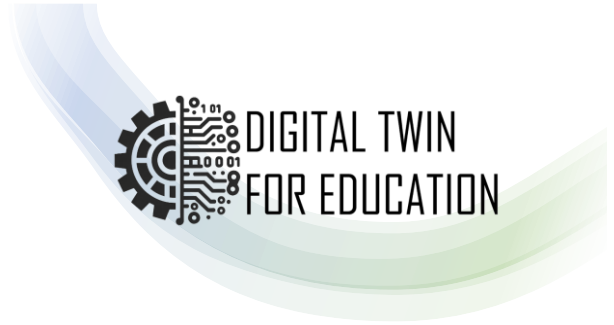

9 Interim test of actuators (cylinders and conveyor belt)

Video: 09Test run

Once all actuators have been integrated, they can be tested manually. To do this, first deactivate all actuators (remove check marks) and start simulation mode using the Run button.

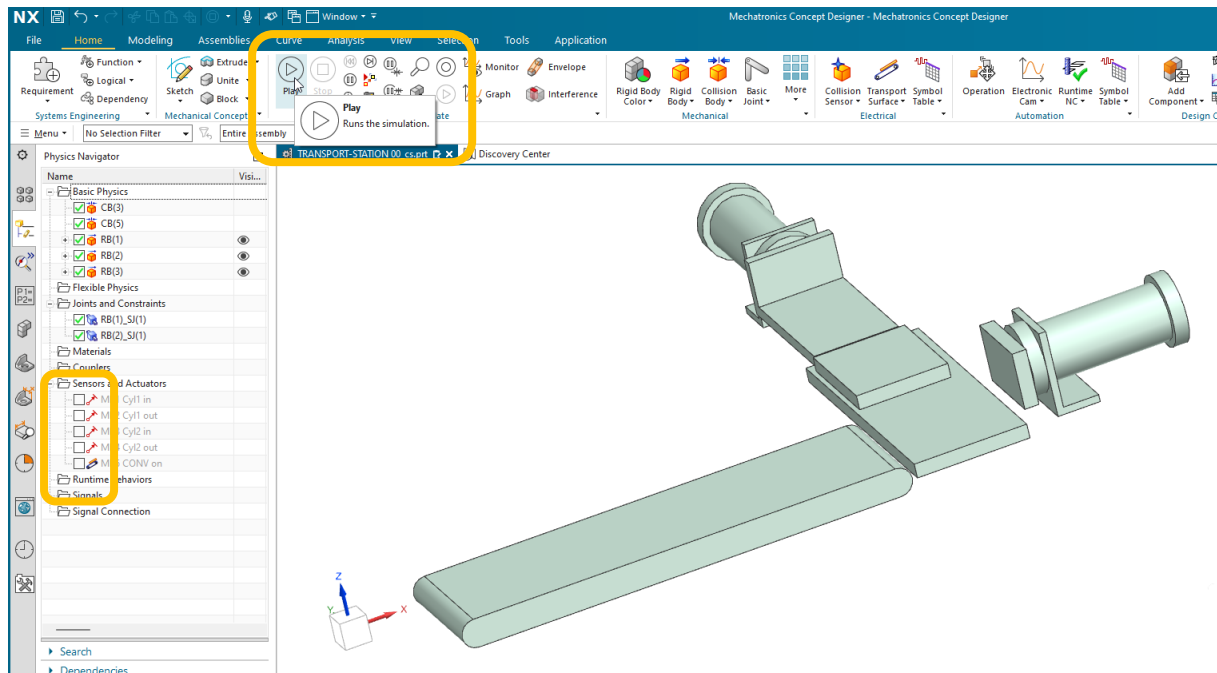

Module 3

Documentation Key Concept Product development

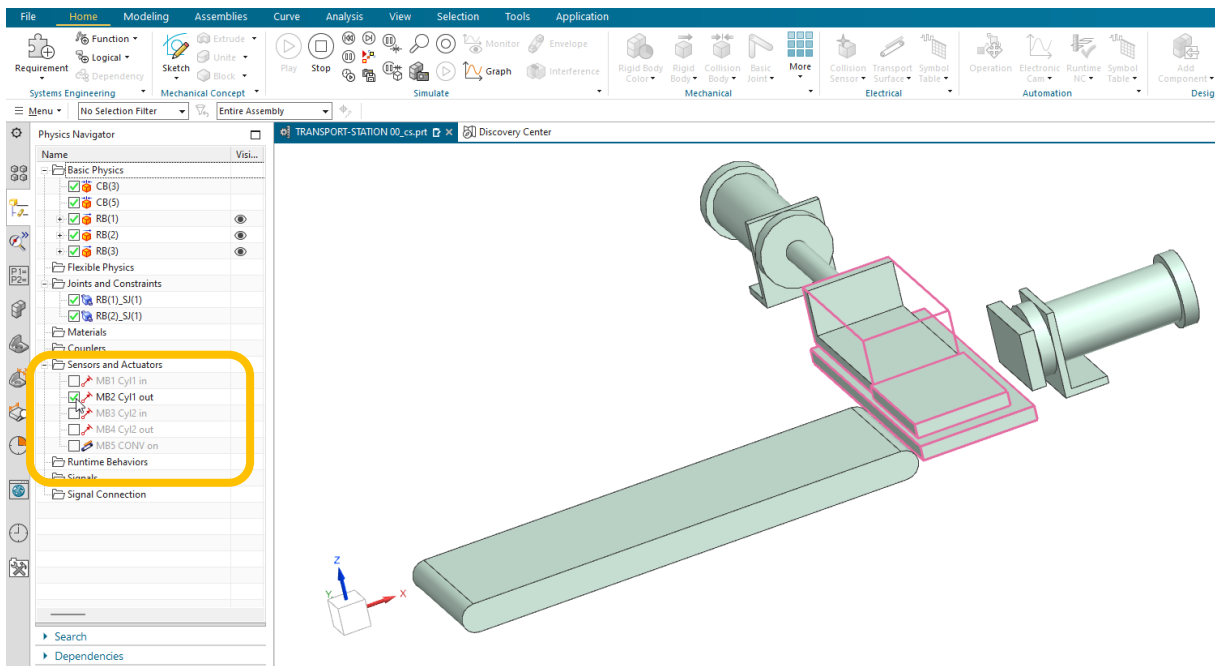
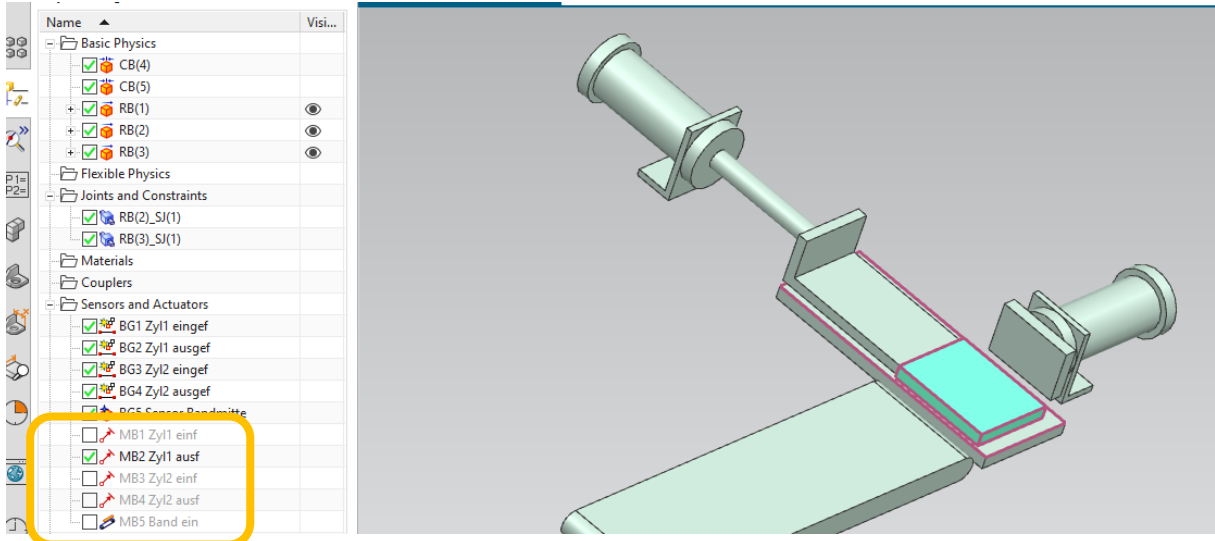
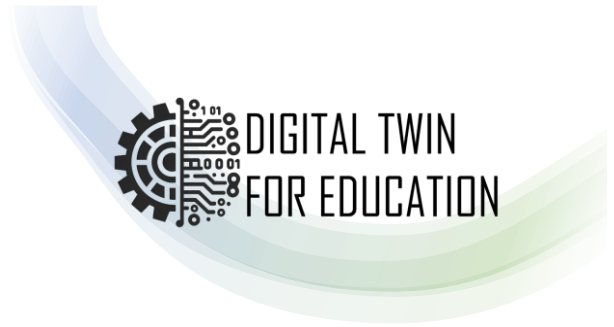

Module 3

Documentation Key Concept Product development

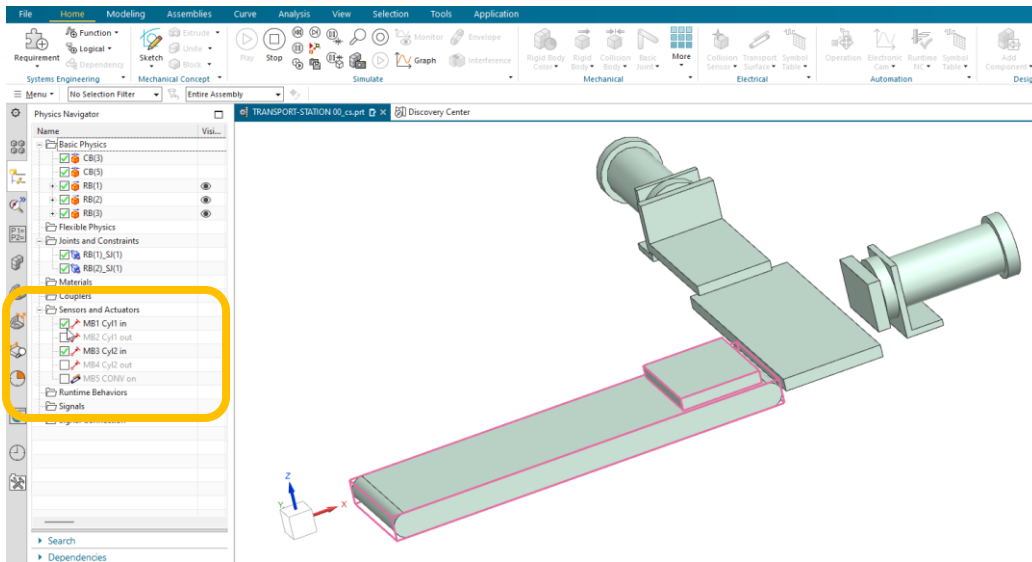
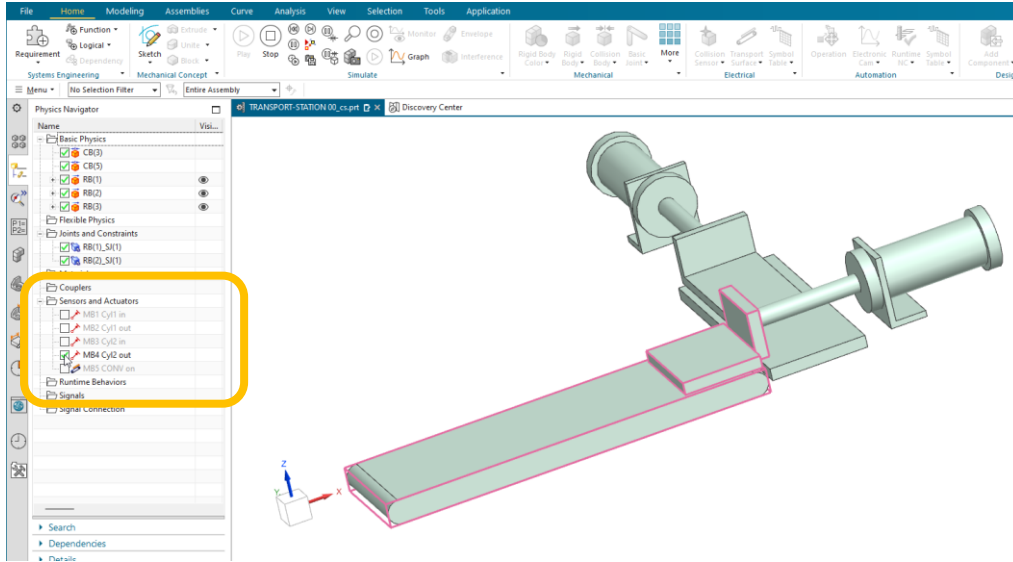

Module 3

Documentation Key Concept Product development

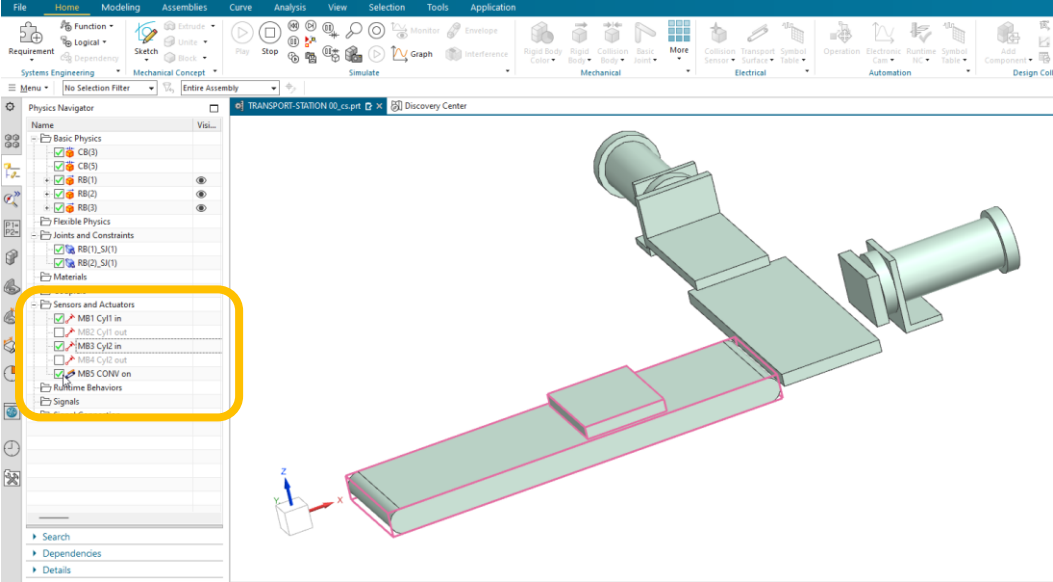
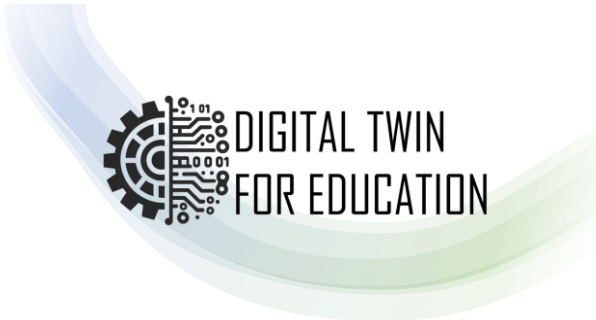

Module 3

Documentation Key Concept Product development

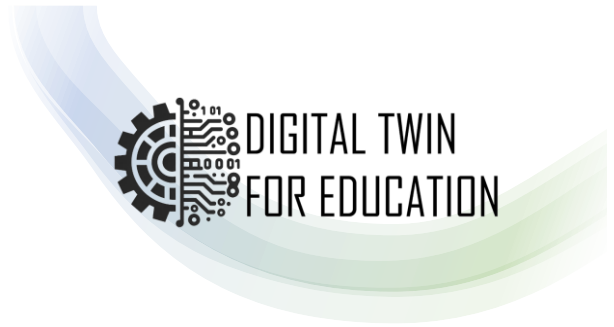

10 Integration of end position monitoring on actuators

Video: 10Limit switches

In the next step, limit position monitoring (sensor limit switches) are to be integrated for the two cylinders. This limit position monitoring is defined with the reference codes BG1/BG2/BG3/BG4.

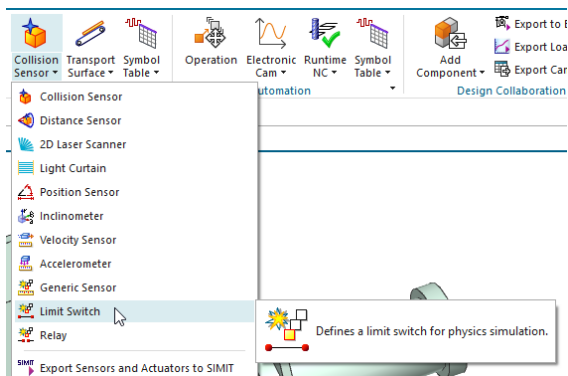

End position monitoring for cylinder 1 retracted → BG1

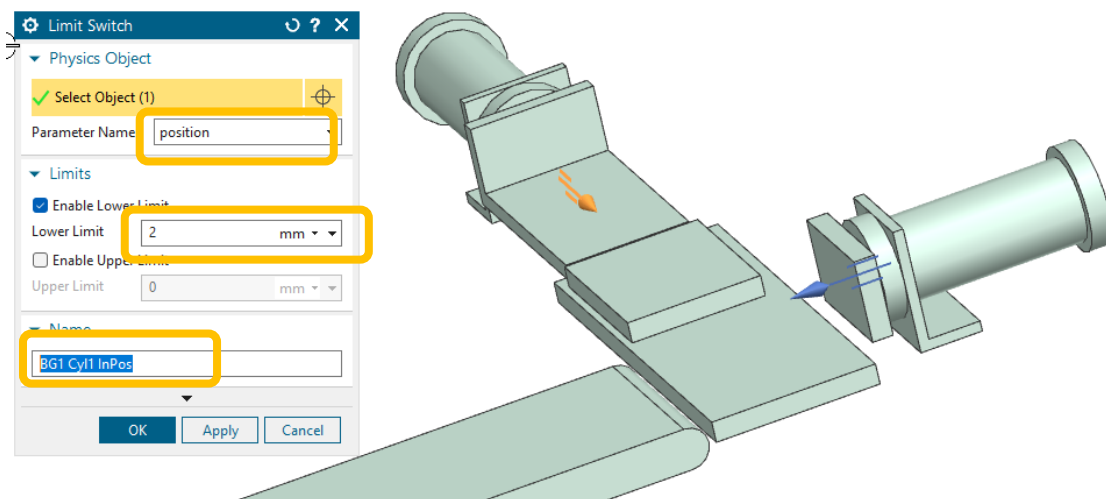

Module 3

Documentation Key Concept Product development

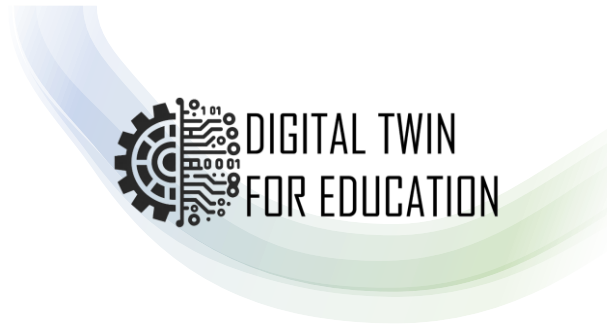

End position monitoring for cylinder 1 extended → BG2

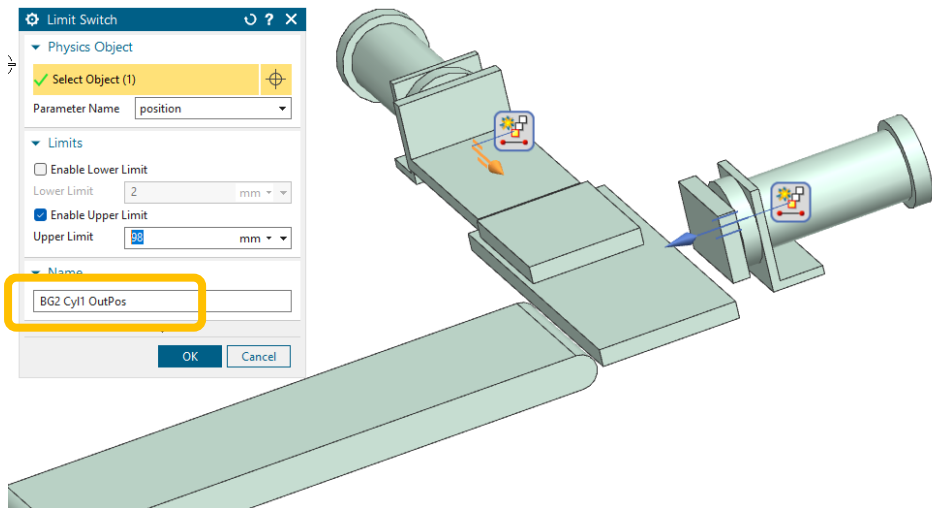

End position monitoring for cylinder 2 retracted → BG3

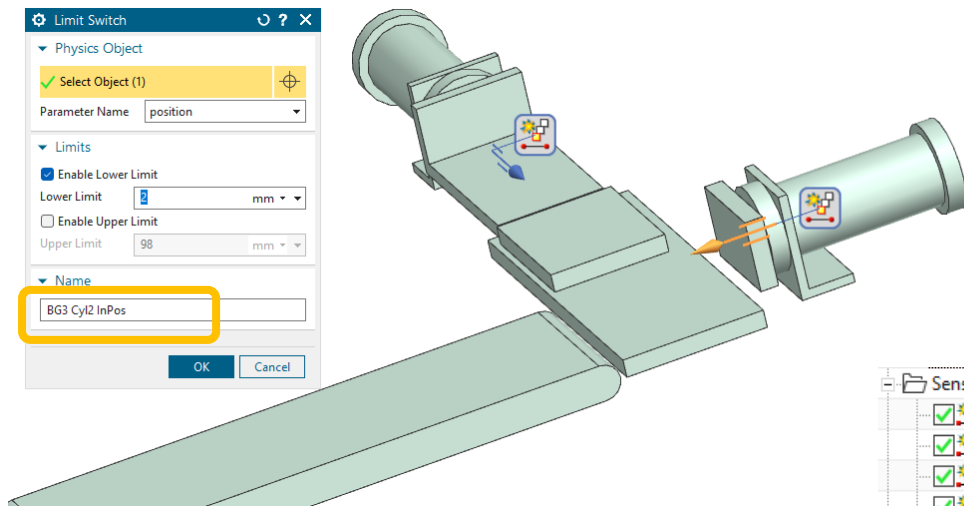

Sensors and Actuators	
<input checked="" type="checkbox"/>	BG1 Cyl1 InPos
<input checked="" type="checkbox"/>	BG2 Cyl1 OutPos
<input checked="" type="checkbox"/>	BG3 Cyl2 InPos
<input checked="" type="checkbox"/>	BG4 Cyl2 OutPos
<input type="checkbox"/>	MB1 Cyl1 in
<input type="checkbox"/>	MB2 Cyl1 out
<input type="checkbox"/>	MB3 Cyl2 in
<input type="checkbox"/>	MB4 Cyl2 out
<input type="checkbox"/>	MB5 CONV on
Runtime Behaviors	

Module 3

Documentation
Key Concept Product development

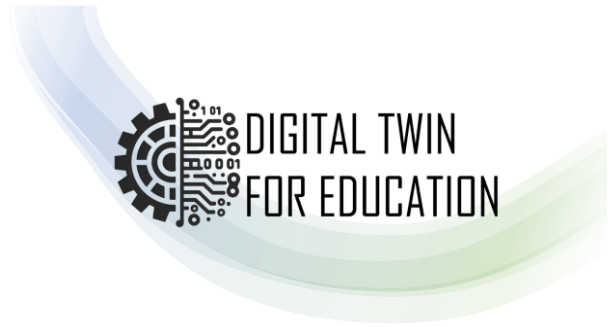

End position monitoring for cylinder 4 retracted → BG4

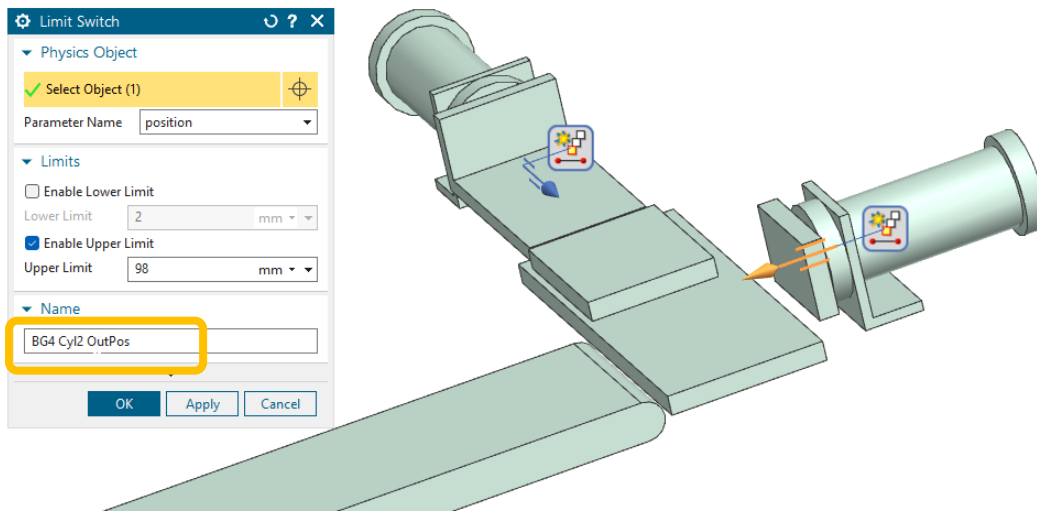

Module 3

Documentation Key Concept Product development

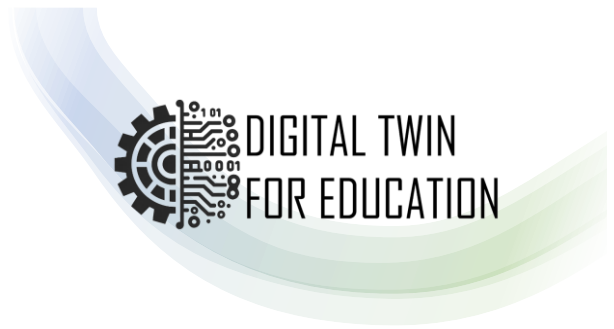

11 Function test of end position monitoring on actuators

Video: 11Test-Limitsw

The Runtime Inspector, a monitoring function, can be used to monitor signals in NX.

If the limit position sensors BG1-BG4 are selected and added to the Inspector, they can be monitored in simulation mode in the view (next image).

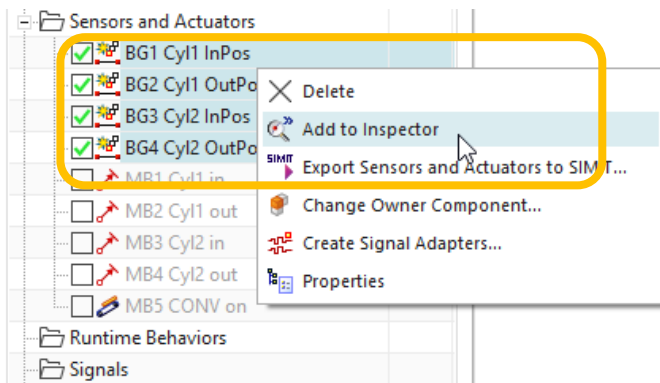

Open the Inspector Window and adjust the size of it

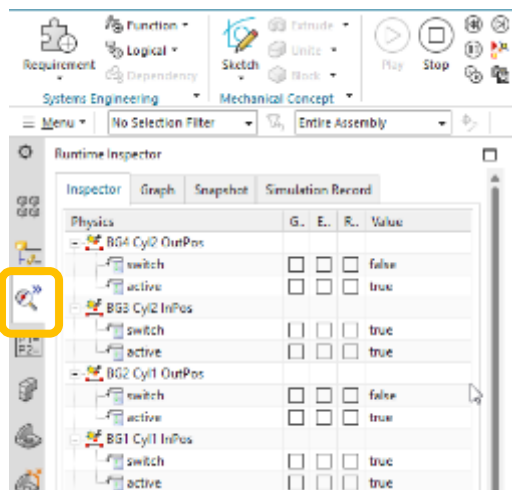

Module 3

Documentation Key Concept Product development

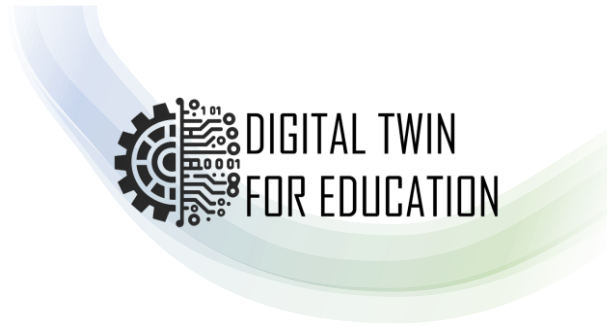

Situation 1: Cylinder 1 is retracted

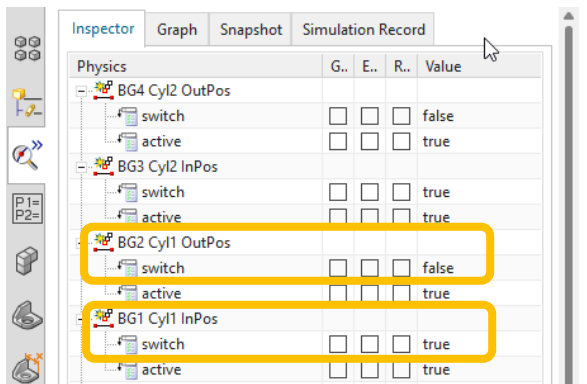
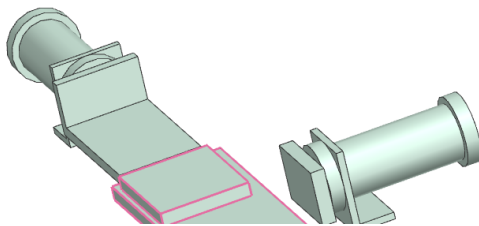

Physics		G..	E..	R..	Value
BG4 Cyl2 OutPos					
switch		<input type="checkbox"/>	<input type="checkbox"/>	<input type="checkbox"/>	false
active		<input type="checkbox"/>	<input type="checkbox"/>	<input type="checkbox"/>	true
BG3 Cyl2 InPos					
switch		<input type="checkbox"/>	<input type="checkbox"/>	<input type="checkbox"/>	true
active		<input type="checkbox"/>	<input type="checkbox"/>	<input type="checkbox"/>	true
BG2 Cyl1 OutPos					
switch		<input type="checkbox"/>	<input type="checkbox"/>	<input type="checkbox"/>	false
active		<input type="checkbox"/>	<input type="checkbox"/>	<input type="checkbox"/>	true
BG1 Cyl1 InPos					
switch		<input type="checkbox"/>	<input type="checkbox"/>	<input type="checkbox"/>	true
active		<input type="checkbox"/>	<input type="checkbox"/>	<input type="checkbox"/>	true

Situation 2: Cylinder 1 is extended

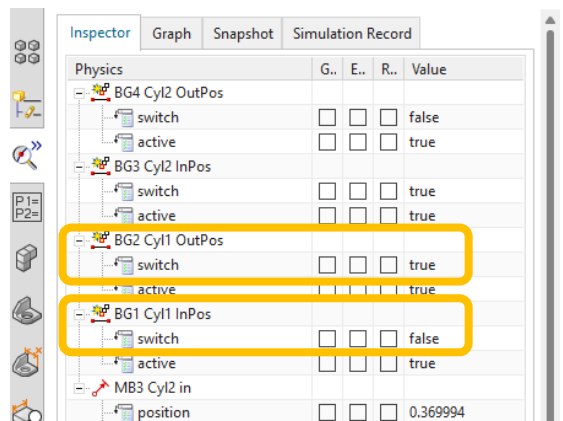
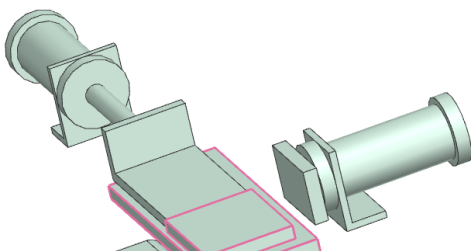

Physics		G..	E..	R..	Value
BG4 Cyl2 OutPos					
switch		<input type="checkbox"/>	<input type="checkbox"/>	<input type="checkbox"/>	false
active		<input type="checkbox"/>	<input type="checkbox"/>	<input type="checkbox"/>	true
BG3 Cyl2 InPos					
switch		<input type="checkbox"/>	<input type="checkbox"/>	<input type="checkbox"/>	true
active		<input type="checkbox"/>	<input type="checkbox"/>	<input type="checkbox"/>	true
BG2 Cyl1 OutPos					
switch		<input type="checkbox"/>	<input type="checkbox"/>	<input type="checkbox"/>	true
active		<input type="checkbox"/>	<input type="checkbox"/>	<input type="checkbox"/>	true
BG1 Cyl1 InPos					
switch		<input type="checkbox"/>	<input type="checkbox"/>	<input type="checkbox"/>	false
active		<input type="checkbox"/>	<input type="checkbox"/>	<input type="checkbox"/>	true
MB3 Cyl2 in					
position		<input type="checkbox"/>	<input type="checkbox"/>	<input type="checkbox"/>	0.369994

Module 3

Documentation
Key Concept Product development

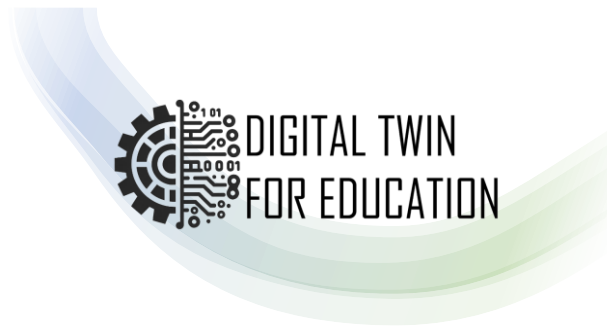

12 Integration of buttons in the NX model

Video: 12Start button

A start button is required to control the model. To do this, you must integrate a geometry into the model that performs the required functionality.

A cylinder that is subsequently integrated into the model and also has the properties of a runtime button takes on the task of initiating the sequence control.

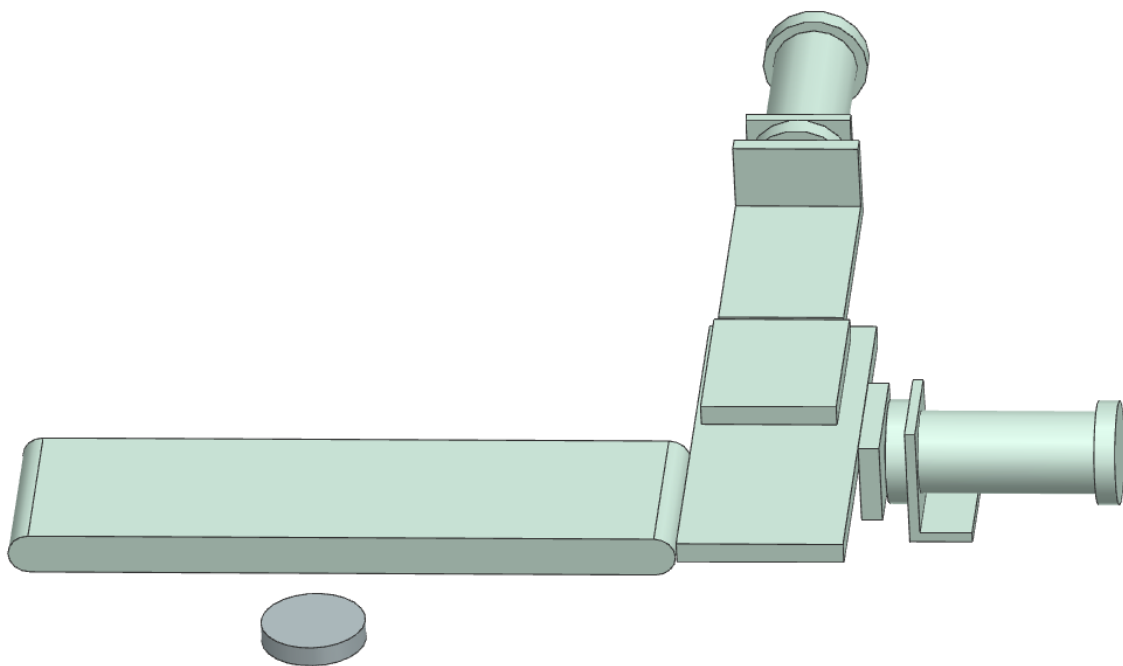

Menu for integrating a cylindrical body into the NX model.

In this case, a cylindrical button is anchored in the model.

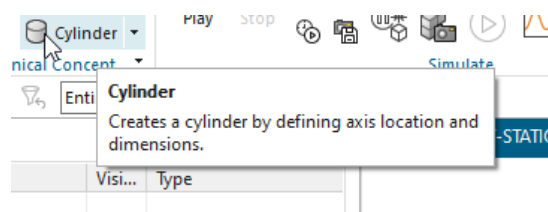

Module 3

Documentation Key Concept Product development

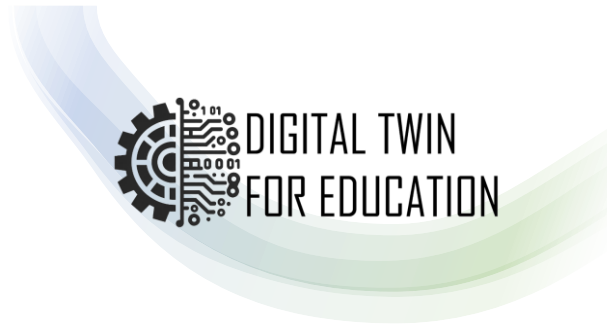

The size, orientation, and position of the button can be varied in the dialog box.

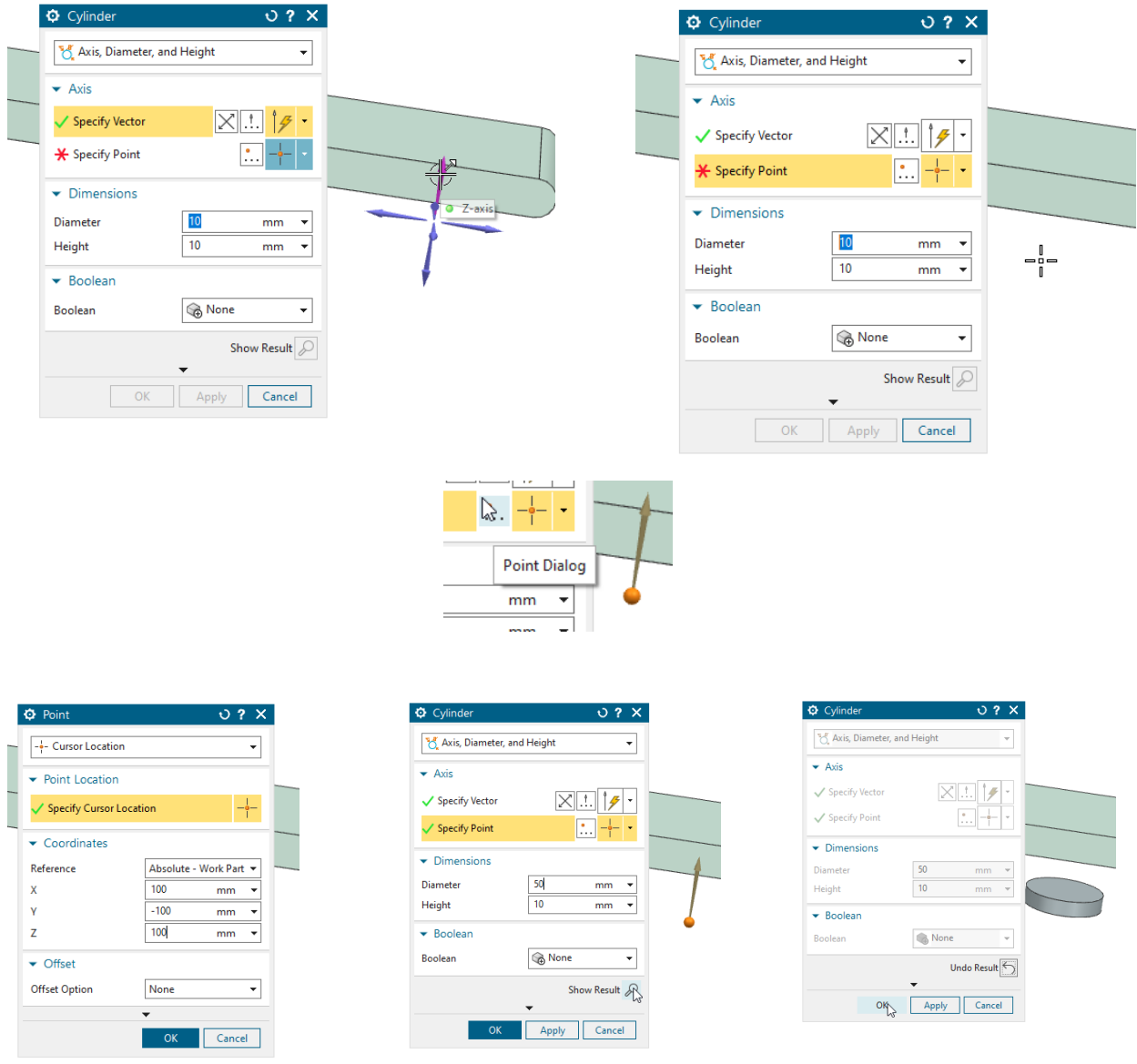

The behavior of the button is then defined. In this case, the button is to transmit a trigger signal to the control system.

Module 3

Documentation
Key Concept Product development

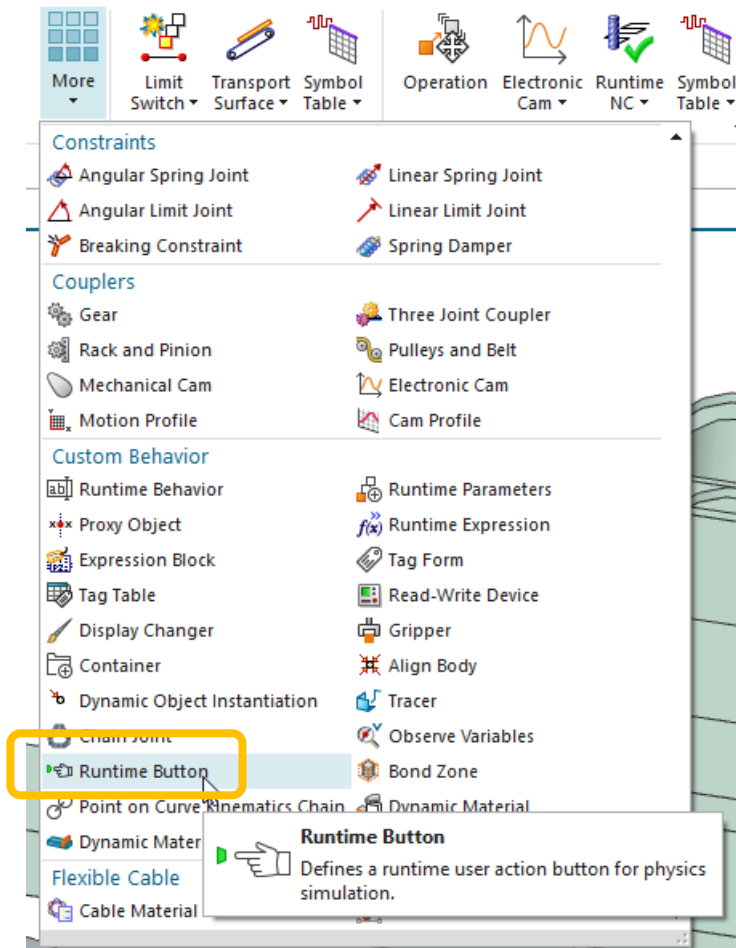
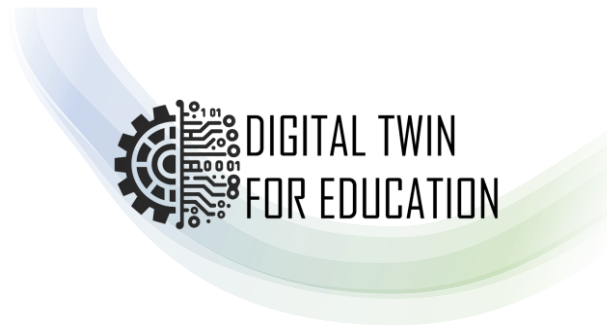

Module 3

Documentation
Key Concept Product development

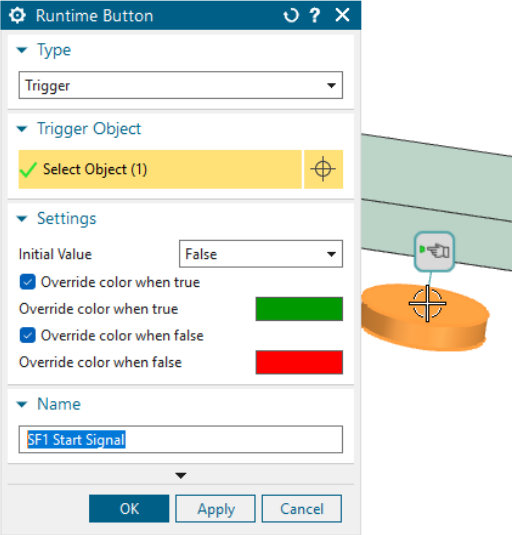
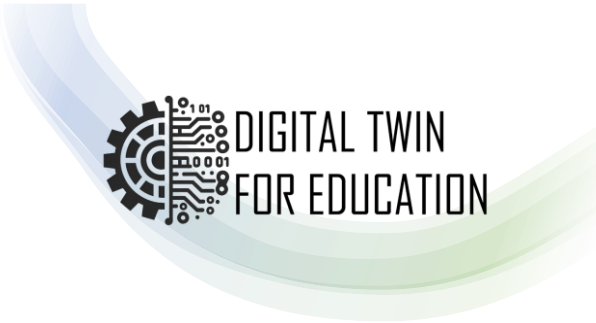

Module 3

Documentation
Key Concept Product development

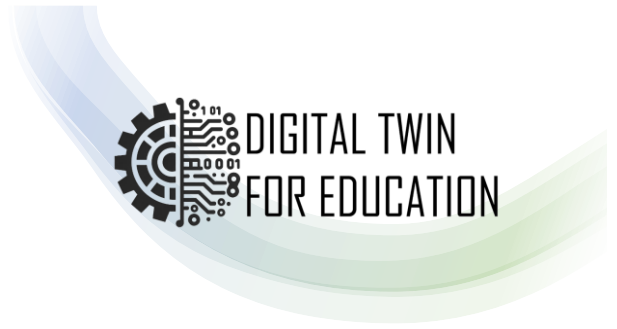

Disclaimer

Funded by the European Union. Views and opinions expressed are however those of the author(s) only and do not necessarily reflect those of the European Union or the European Education and Culture Executive Agency (EACEA). Neither the European Union nor EACEA can be held responsible for them.