

DIGITAL TWIN FOR EDUCATION

The Theory of the Digital Twin
Module 1

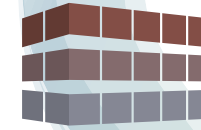

CARL-BENZ-SCHULE
GAGGENAU



Mercantec



Co-funded by
the European Union

What is a Digital Twin?



- Definition:

Digital/virtual representation of a physical product, system, or process

- Three elements:

- Physical Twin (Real Space)
- Digital Twin (Virtual Space)
- Digital Thread (Data link)

What is a Digital Twin?

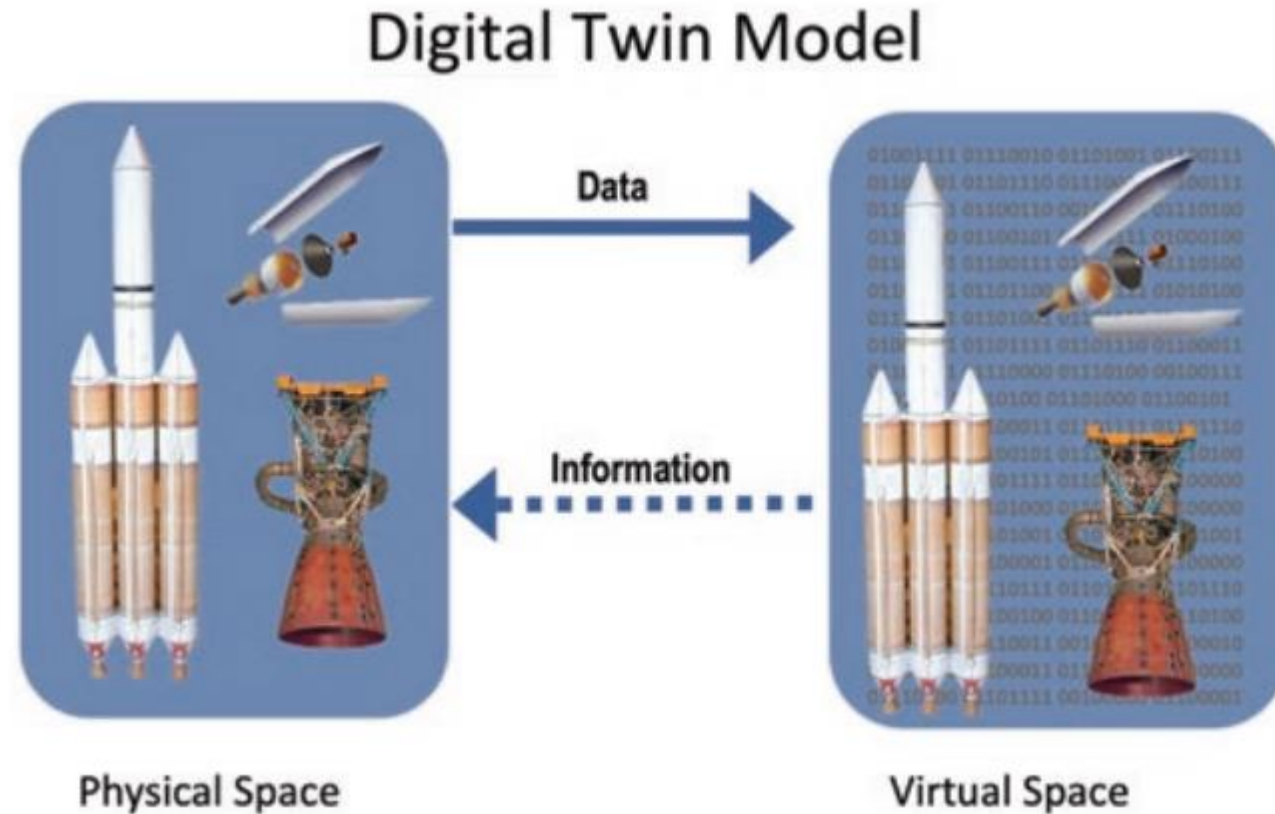

Digital Twins: Past, Present, and Future (2023)
- Michael W. Grieves

Digital Representations

- Digital Model (digital → physical)
- Digital Shadow (physical → digital)
- Digital Twin (two-way sync)



Historical Background



- Apollo 13 – early “proto twin”
- Computer simulations (Von Neumann, Ulam, Shakey robot)
- First use of the term (1997)
- Defined in 2002, widely adopted by 2018

Types of Digital Twins



- Prototype (DTP) – virtual design/testing
- Instance (DTI) – specific unit with data
- Aggregate (DTA) – collection of DTIs, predictive analytics

Examples of Digital Twins

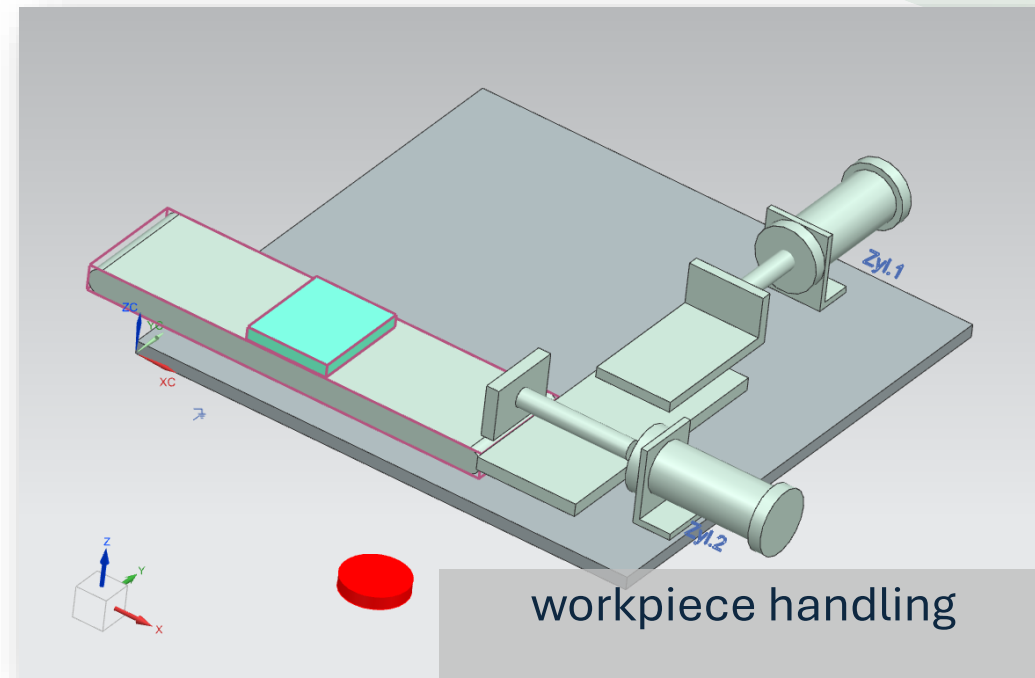
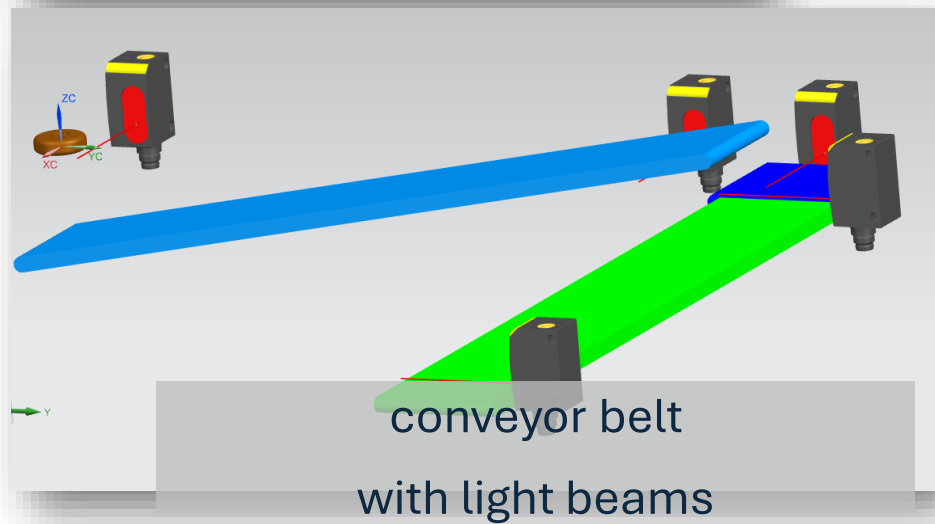
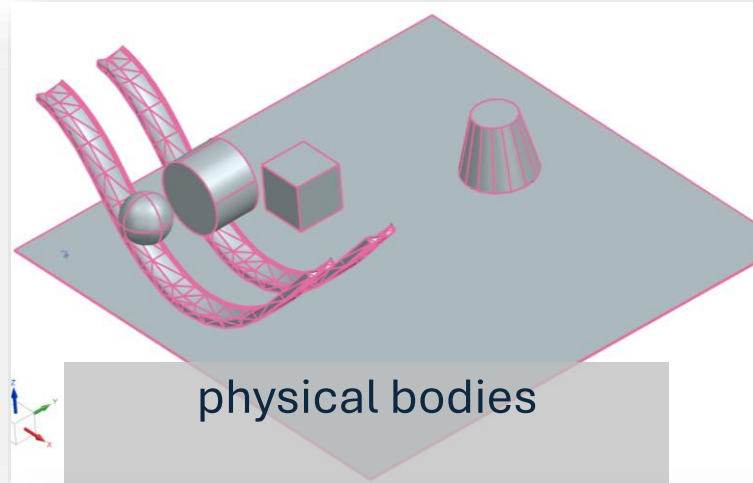

Examples of Digital Twins

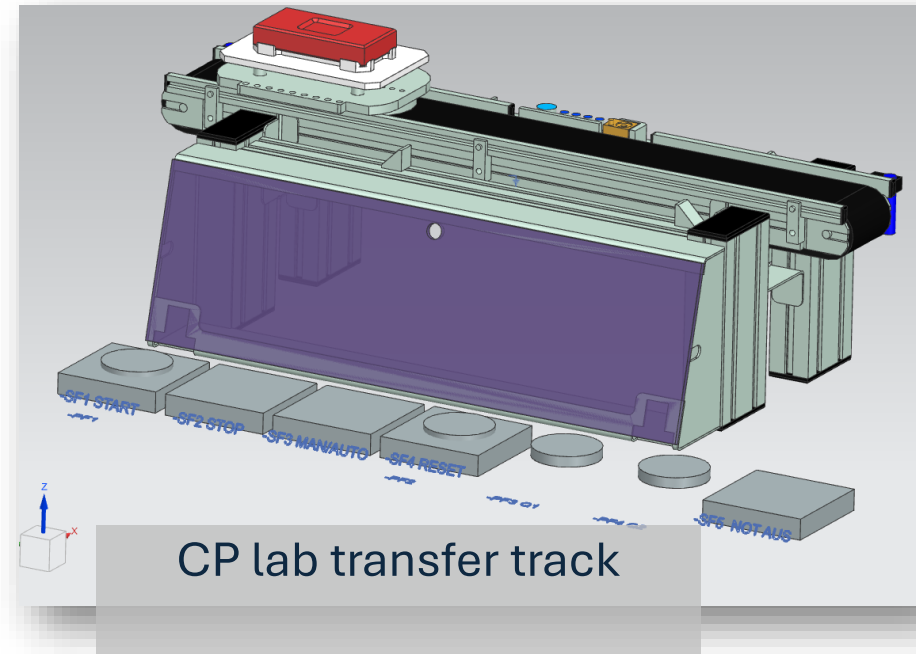
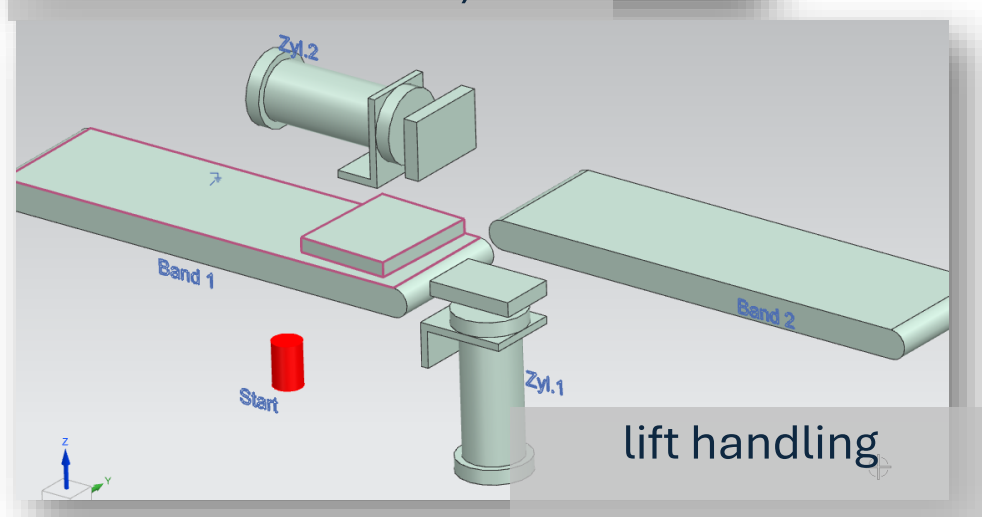
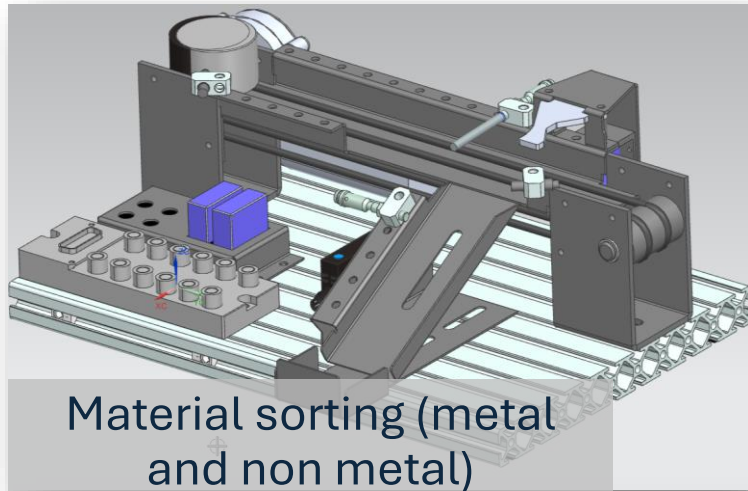

Types of Digital Twins

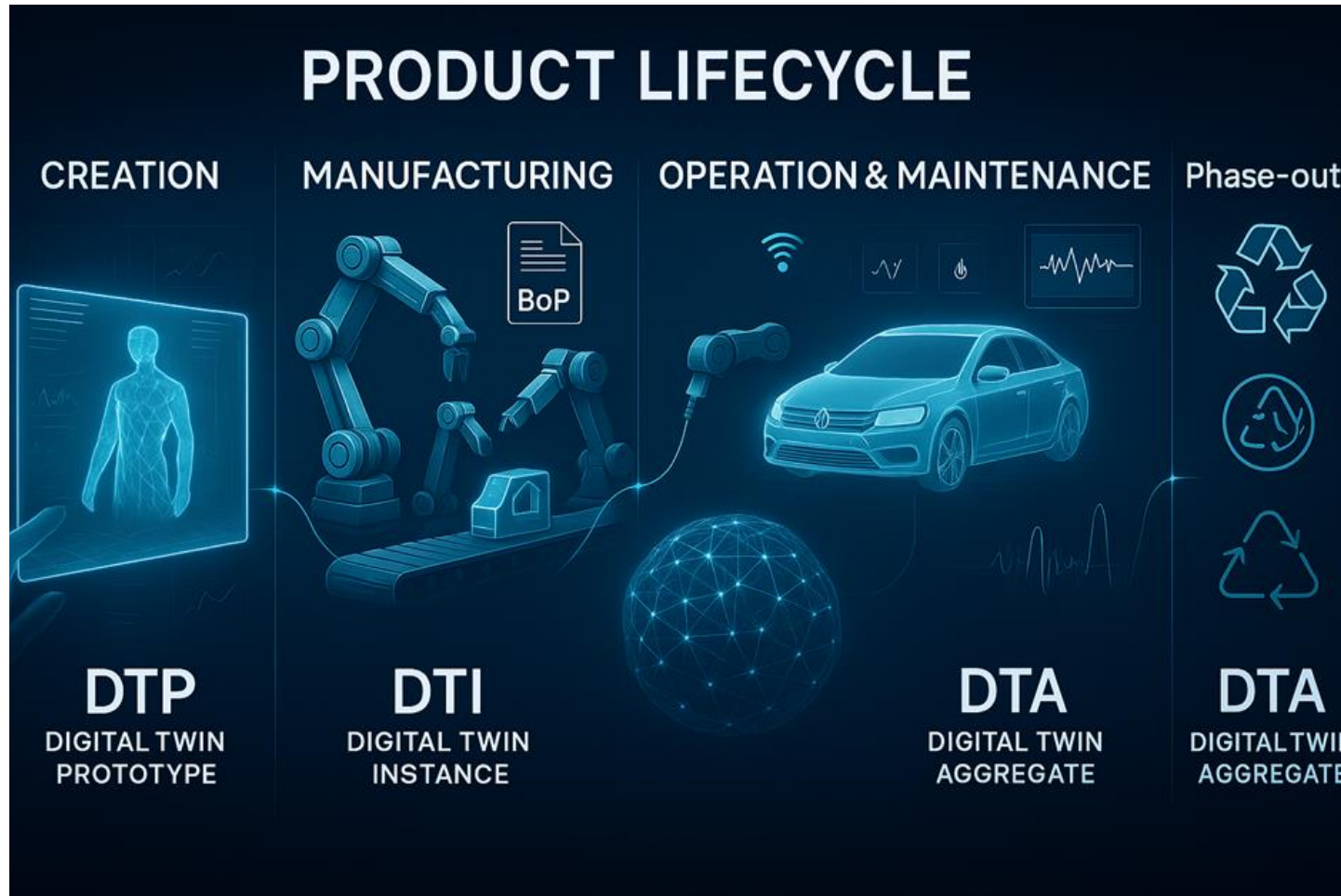

Twins in the Product Lifecycle



- Four phases: Create – Manufacture – Operate – Phase-out
- Twins applied across all stages

Evolution of Digital Twins



- Phase 0: Traditional (drawings, CAD)
- Phase 1: Transitional (3D models)
- Phase 2: Conceptual (data experiments)
- Phase 3: Replicative platforms (today)
- Phase 4: Intelligent Twins (AI-driven, predictive)

Evolution of Digital Twins

Digital Twin Evolution

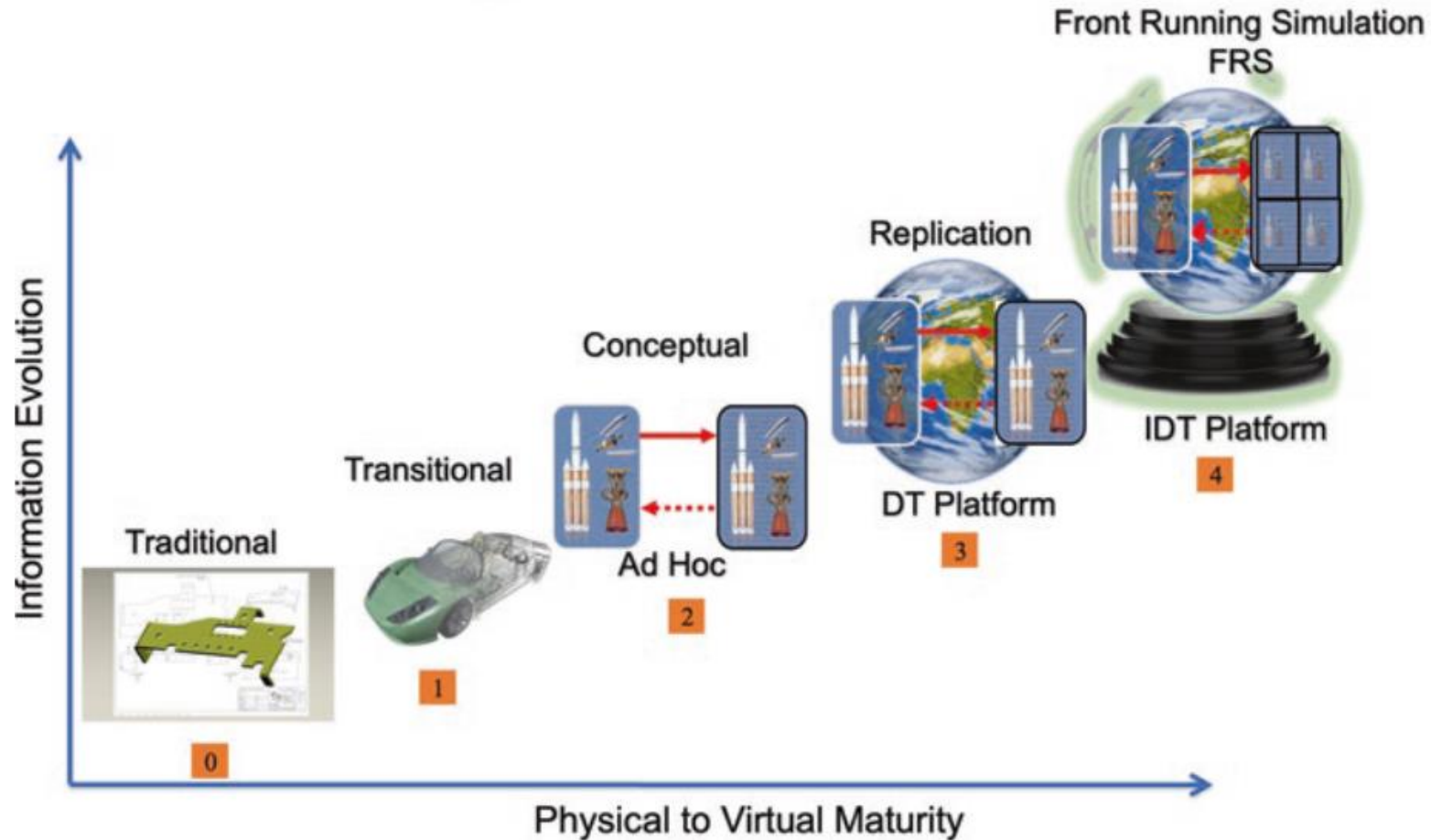

Simulation & Testing

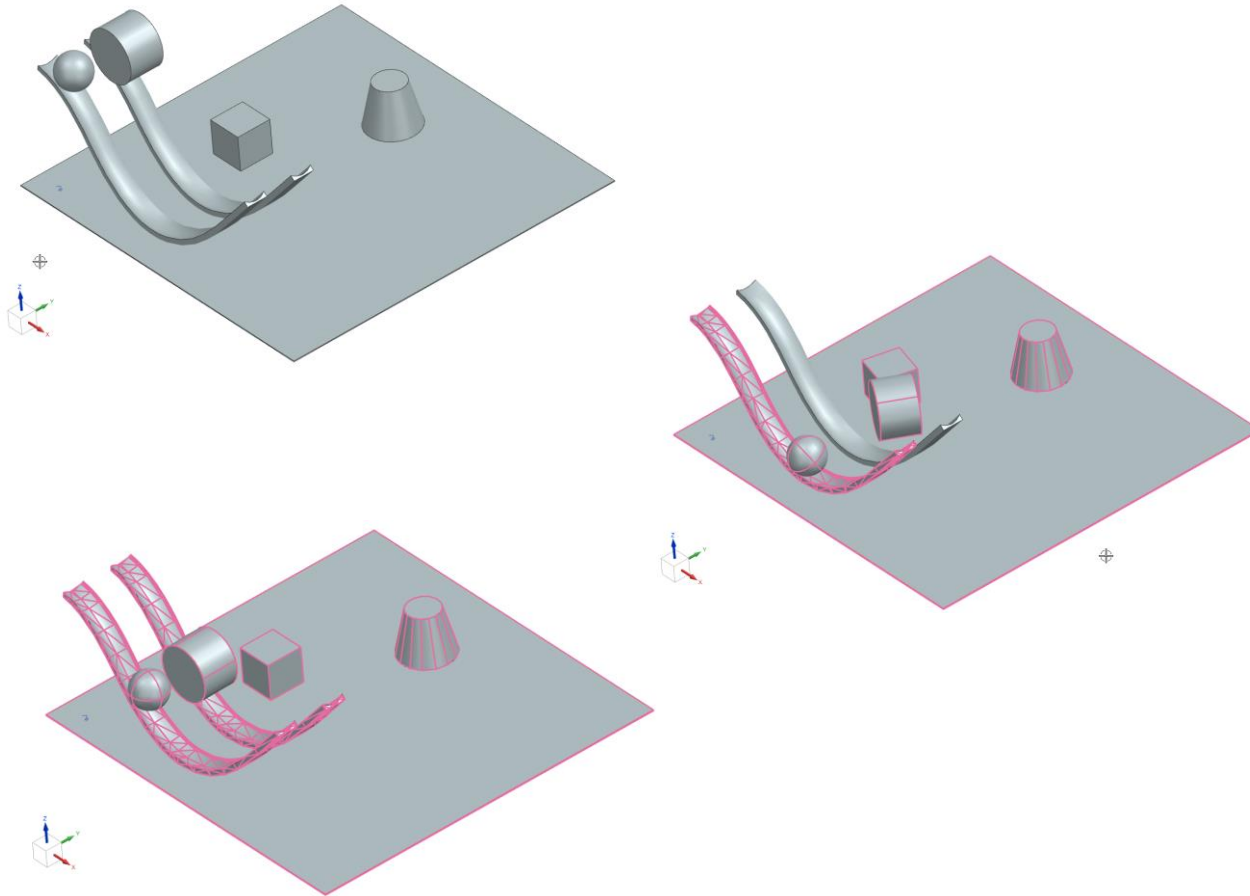

The digital models can be given physical properties (e.g. density, friction, ...). Thus, the model behavior corresponds to the real behavior. The bodies roll down the ramp at different speeds. Also bodies can leave the ramp.

Simulation & Testing

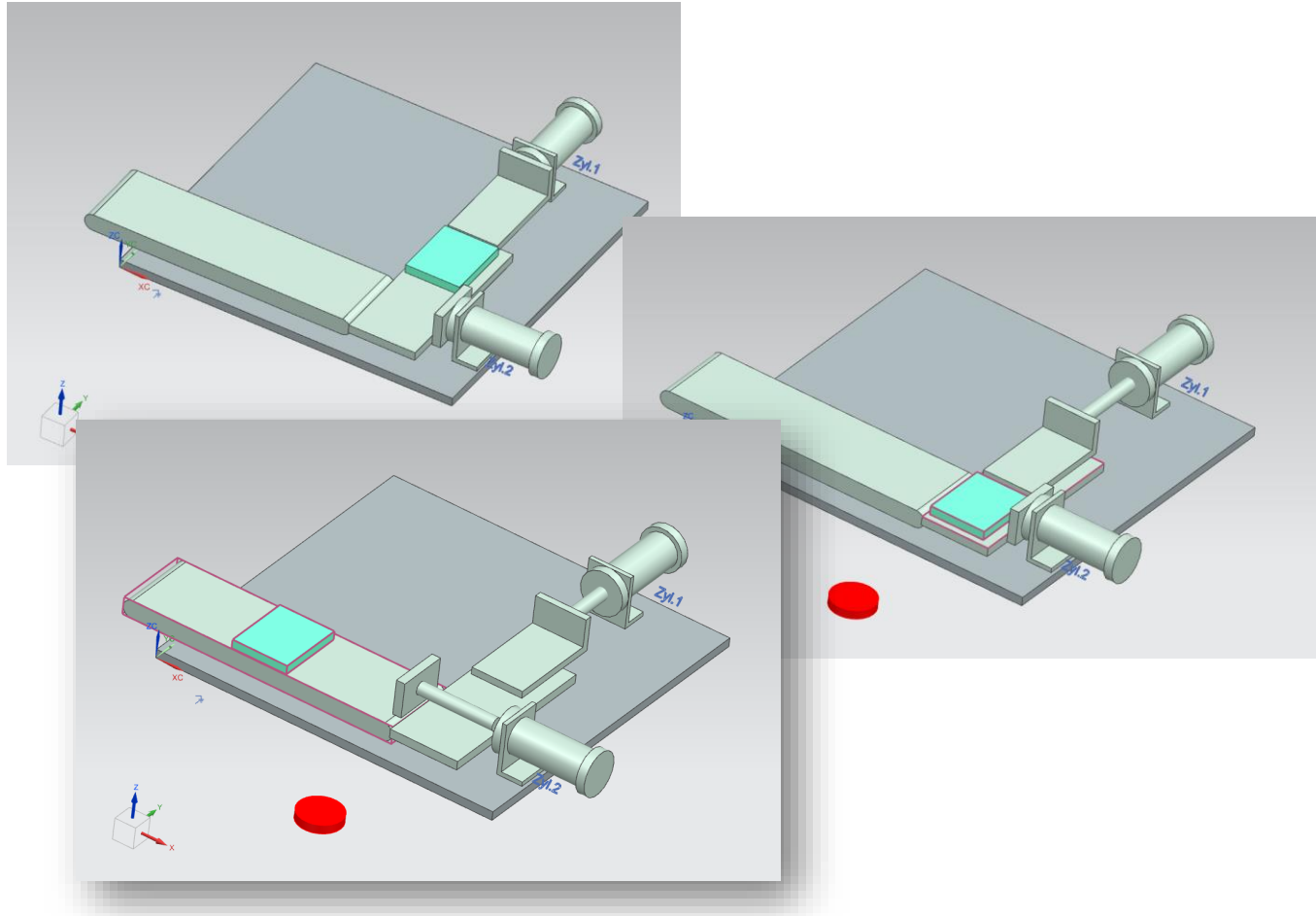

Digital pneumatic cylinders extend and transmit a force to the workpieces so that they reach the next conveyor belt. The cylinders can be integrated into PLC programming and controlled.

Simulation & Testing



- Model = Static
- Simulation = Dynamic
- Grieves' Tests of Virtuality:
 - Visual, Performance, Reflectivity, Prediction

Advantages of Digital Twins

- Real-time monitoring
- Predictive maintenance
- Fewer physical prototypes
- Better documentation & traceability



Challenges / Disadvantages

- High costs
- Data integration complexity
- Cybersecurity risks
- Skills & training required



Challenges / Disadvantages

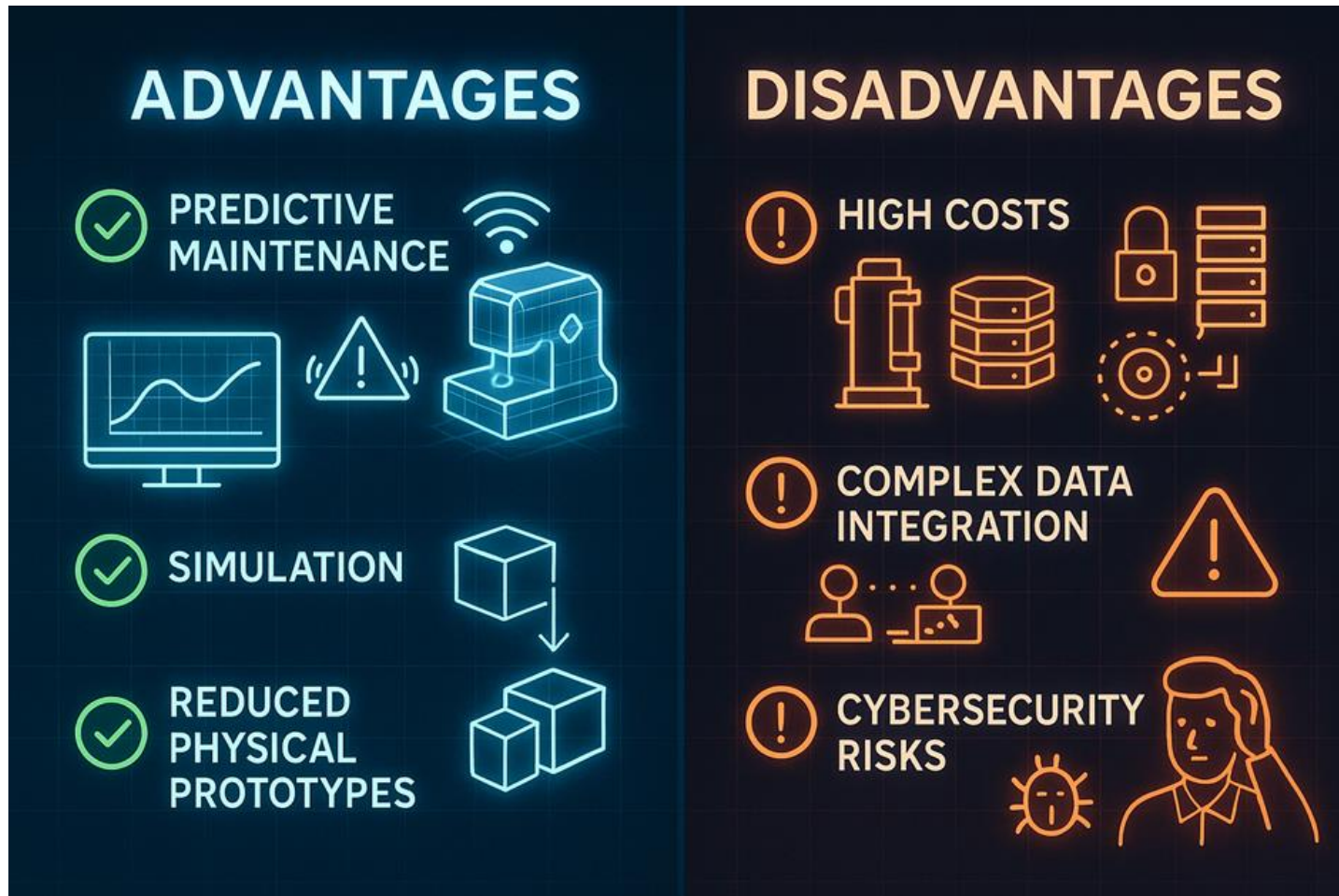

Digital Twins in Education



- Safe, repeatable learning environments
- Flipped & blended learning support
- Risk-free practice for students
- Challenges: cost, time, training

Hardware & Software for Digital Twins



- **Hardware (Education):**
 - Powerful PC (CPU, GPU, RAM, SSD)
 - VR/AR devices (Oculus Quest, HTC Vive, HoloLens)
- **Hardware (Industry):**
 - IoT sensors & edge computers
 - Servers & cloud platforms (Azure, AWS, MindSphere)
- **Software:**
 - **3D modeling:** Autodesk Inventor, Fusion 360, SolidWorks
 - **Simulation:** Ansys, COMSOL
 - **Data analysis & visualization:** Power BI, Python, MATLAB
 - **Interactivity & VR:** Unity, Unreal Engine

The Future of Digital Twins

- Intelligent Twins (AI + simulation)
- Predictive “crystal ball” systems
- From reflection → proactivity
- Decision-making partner



Conclusion

- Digital Twins = bridge between concept & reality
- Useful across entire lifecycle
- Relevant for both industry & education
- From digital mirror → intelligent collaborator



Conclusion

